



QUARTER SCALE AUTO CLUB, Inc.

Website <http://www.qsac.org>



2011 Official Rules Package and Corporate Bylaws

Copyright © 2003-2011 [QSAC, Inc] All rights reserved.
Other products and companies referred to herein are trademarks
or registered trademarks of their respective companies or mark holders

Table of Contents

Introduction	3	<ul style="list-style-type: none"> ▫ Pit / Fuel Stops - Red Flag ▫ Pre-Race Technical Inspection ▫ Post-Race Technical Inspection ▫ Drivers and Pit Crews ▫ Un-Sportsmanlike Conduct ▫ Protests ▫ Backup Car and Body ▫ Track Fuel ▫ Scoring The Tie Breaker ▫ Rain Out Rule ▫ "The Final Showdown" Format ▫ QSAC Showdown N.C.S. "District" Race Day Schedules ▫ QSAC Showdown N.C.S. "Final Showdown" Schedule 	
QSAC Calendar.....	3	2011 QSAC Dirt Oval Sprint Car National Championship.....	17
QSAC Showdown N.C.S. Races.....	4	General Car Specifications	20-21
Prior Year QSAC National Champions.....	5	<ul style="list-style-type: none"> ▫ Engine ▫ Exhaust ▫ Carburetor ▫ Clutch ▫ Ignition Module ▫ Fuel ▫ Fuel System ▫ Car Numbers ▫ Chassis ▫ Tires and Wheels ▫ Miscellaneous ▫ Impact Parts 	
QSAC Partners Contact Info.....	5	Body Manufacturer Specifications	22
Safety Requirements	6	Quarter Scale Car Manufacturers.....	22
General Requirements	7	Grand National Stock Car Specifications	23
Track Sanctioning and Construction Requirements	7	Sportsman Stock Car Specifications.....	23
Cash Purse Payout Schedule.....	7	Novice Stock Car Specifications.....	24
Race-Day Schedule of Events.....	8-9	Super-Truck Specifications	24
<ul style="list-style-type: none"> • Sign In and Registration • Practice • Driver's Meeting • Concourse' • Pre-Race Tech Inspection • Pill Draw or Single Car Qualifying • Trophy Dashes (optional) • Heat Races • Main Events • Post Race Tech Inspection 		Sprint Car Specifications.....	24
<ul style="list-style-type: none"> ▫ Awards 		Super Modified Specifications	24-25
Race Format - Procedures	10-11	East Coast Modified Specifications.....	25
<ul style="list-style-type: none"> ▫ Standardized Entry Fees ▫ Flagman Race Starts ▫ Yellow Flag ▫ Restarts ▫ Checkered Flag ▫ Black Flag ▫ Pit Stops - Refueling - Red Flag Stops ▫ Driver - Pit Crew ▫ Un-Sportsmanlike Conduct ▫ Protests 		Drag Racing Specifications	25
		Engine Technical Inspection Procedure.....	25
		Sprint Car Rules.....	26-29
		QSAC Sanctioned Tracks In 2006.....	30
		QSAC Corporate By-Laws	31-35
		QSAC Organizational Chart.....	36
		QSAC Suggestion Form	37
		QSAC Membership Registration.....	38-39
QSAC Showdown National Championship Series.....	12-19		
<ul style="list-style-type: none"> ▫ Introduction ▫ Awards ▫ QSAC N.C.S. District Format ▫ Single Car Qualifying ▫ Heat Races ▫ Mains ▫ Initial Race Starts and Re-starts ▫ Yellow Flag ▫ Checkered Flag ▫ Black Flag 			



Hello and welcome to the *2011 QSAC Official Rules Package and Corporate Bylaws*

We are recommending no changes be made to the 2011 QSAC Rulebook until January 1st, 2012. The only exceptions to this would be that existing rules need to be clarified and a manufacturer product name and/or model number changes beyond our control. It is the intent of the QSAC leadership team to provide the membership with a stable set of rules for the next two years and beyond. In 2012, the rules will be revisited, but it is our belief that stable and consistent rules is a benefit to the membership and helps position QSAC for future growth.

QSAC STATEMENT (11.24.05)

Any rule change (s) submitted by any QSAC Official or Committee that may directly effect the manufactured product of a QSAC approved manufacturer (s), must be presented in writing to the Manufacturer's Advisory Committee Chairman for evaluation. Such proposed rule amendments shall be voted on by all of the QSAC approved manufacturers in a timely manner. The Manufacturer's Advisory Committee Chairman will present their recommendation (s) to the QSAC Official or Committee. The QSAC Co-Chairs and the Manufacturer's Advisory Committee Chairman shall work closely together to determine which proposed rules should be submitted for evaluation.

TECHNICAL COMPLIANCE RESPONSIBILITY

It is the responsibility of each driver to insure his/her Quarter-Scale Race car is in total compliance with all applicable QSAC Rules. This means Safety, General and Technical Specifications as defined herein. It is important that each competitor read and understands all of the rules as they apply to safety, race format, driver-conduct, and technical specifications. Ignorance of the Rules is not a defense for violation of them. Failure to comply may result in immediate disqualification, loss of points for the event and further action as deemed necessary by QSAC.

2011 QSAC Calendar

February.....[First Newsletter](#)

April 15 , 16.....**QSAC Showdown N.C.S. (Eastern District Race #1)**

Hosted by: Lakeside Speedway, Clover, South Carolina

April.....[Second Newsletter \(Online Version Only\)](#)

May 13 , 14.....**QSAC Showdown N.C.S. (Central District Race #1)**

Hosted by: Machesney Park, Machesney Park, Illinois

June 10 ,11.....**QSAC Showdown N.C.S. (Western District Race #1)**

Hosted by: DFW Speedway, Burleson, Texas

June.....[Third Newsletter](#)

July 15 , 16.....**QSAC Showdown N.C.S. (Eastern District Race #2)**

Hosted by: Freddie's Hobbies, Ranenna, Ohio

August 19 , 20.... **QSAC Showdown N.C.S. (Central District Race #2)**

Hosted by: Indy Quarter Scale Racers, Ingalls, Indiana

DATE TBA... **QSAC Dirt Oval Nationals.**

Hosted by: TBA

August 1st.....Deadline for 2012 QSAC Suggestions

August 1st.....Mail out Co-Chair ballot and 2011 QSAC Questionnaire

This will be the only mass mailing to the QSAC membership.

September 1st.....Deadline for QSAC Co-Chair Ballot

September 23 , 24...**QSAC Showdown N.C.S. (The Final Showdown).**

Hosted by: Orange Show Quarter Midget Association, San Bernardino California.

[September.....Fourth Newsletter \(Online Version Only\)](#)

October 1st...Deadline for 2012 QSAC Race Event Bid Package

January 1st 2012.....2012 Rules Package announced

December 1st 2012.....2012 QSAC Race Locations announced

[December.....Fifth Newsletter](#)

2010 QSAC Showdown N.C.S.

1. Burleson, TX
Central District
N.C.S. Race #1

Grand National
1. Curtis Babbit
2. Jeff Davis
3. Wayne Babbit

Sportsman
1. Randy Brown
2. Jim Bell
3. Will Landers

Sprint Car
1. DC
2. Mike Saddler
3. Mike Watkins

Super Truck
1. Mike Sadler
2. Curtis Babbit
3. Orrin Sunde

2. Bolder City, NV
Western District
N.C.S. Race #1

Grand National
1. Ritchie Abbot
2. Jim Turner
3. Jim Pelletior

Sportsman
1. Scott Dave
2. Randy Brown
3. Steve Ballew

Sprint Car
1. John Whisenand
2. Bob Leydecker
3. Mike Beacham

Super Truck
1. Mike Dill
2. Mike Beacham
3. Jim Davy

3. Easley, SC
Eastern District
N.C.S. Race #1

Grand National
1. Brent Gottfried
2. Jeff Davis
3. Will Landers

Sportsman
1. Tim Smith
2. Sam Presnell
3. Jeff Burnett

Sprint Car
1. Jeff Davis
2. Mike Sadler
3. Murray Pipchok

Super Truck
1. Jeff Davis
2. Orrin Sunde
3. Danny Porcase

4. Pasco, WA
Western District
N.C.S. Race #2

Grand National
1. NA
2. NA
3. NA

Sportsman
1. Chance Overholt
2. Brian Lambert
3. Randy Sides

Sprint Car
1. NA
2. NA
3. NA

Super Truck
1. Jim Bise
2. Zach Pfister
3. Mike Dill

5. Montgomery, AL
Eastern District
N.C.S. Race #2

Grand National
1. Brent Gottfried
2. Jeff Davis
3. Will Landers

Sportsman
1. Randy Brown
2. Jerry Evans
3. Bubba Coker

Sprint Car
1. DC
2. Randy Baker
3. Larry Hopson

Super Truck
1. Randy Brown
2. JR Hartley
3. Bob Claussen

6. Algona, IA
The Final Showdown
N.C.S. Race

Grand National
1. NA
2. NA
3. NA

Sportsman
1. Scott Schramske
2. Jon Smith
3. Rodger Newell

Sprint Car
1. DC
2. Jim Patton
3. Randy Baker

Super Truck
1. Mike Sadler
2. Jeff Davis
3. John Brennen



Congratulations to our

2010 QSAC Showdown N.C.S. Champions

Grand National	Jeff Davis
Sportsman	Randy Brown
Sprint Car	DC
Super Truck	Mike Sadler

QSAC PARTNERS CONTACT INFO

"A Cut Above" by Bob Elliott

Ask for Bob
(563) 355-5787
E-mail: acaelliot@aol.com

Bob's Motorsports

Ask for Bob
(702) 210-3961
E-mail: bobsmotorsports@hotmail.com

Bishop Racing Products (BRP)

Ask for Todd
(479) 751-6232
E-mail: tbishop44@cox-internet.com
<http://bishopracingproducts.com>

Cat 5 Manufacturing

Ask for Scott
(832) 928-3543
E-mail: cat5mfg@quarterscalecar.com
<http://www.quarterscalecar.com>

Ferguson Racing

Ask for John
(909) 556-5083
E-mail: LJJPf@aol.com
<http://www.fergusonracing.com>

Hendershot Racing

Ask for David
(866) 951-2112
E-mail: hremotorsports@verison.net

Holloway Vinyl Signs & Graphics

Ask for Todd
(765) 759-9703
E-mail: stickwithholloway@comcast.net
<http://www.stickwithholloway.com>

JR Quarter Scale

Ask for Freddie
(330) 296-4354
E-mail: freddie@freddiesasphaltoval.com

Pit Road Racing

Ask for Fred
(937) 475-4016
E-mail: fmurry8995@aol.com

Pro 1 Racing

Ask for Jim
(405) 584-2510
E-mail: pro1@pro1z.com
<http://www.pro1z.com>

Pro Scale Motorsports

Ask for Randy
(231) 834-7707
E-mail: circletrac@triton.net

QS Components, inc.

Ask for Frank
(888) 871-1210
E-mail: qscinc@excite.com
<http://qscomponents.com>

Quarter Scale Motorsports

Ask for Larry
Toll Free (800) 266-7745
E-mail: Larry@quarterscalemtrsports.com
<http://www.quarterscalemtrsports.com>

Rick's Body & Paint

Ask for Rick
(515) 295-2159
E-mail: rwwheels@netamumail.com

SAFETY REQUIREMENTS

1. All drivers, officials, and pit crew members/mechanics must be current members of QSAC to enter the track, hot pit or paddock.
2. The QSAC membership-insurance card or receipt of application must be displayed at all times during the racing event and must be presented when signing in.
3. Race promoters/Track owners must be able to show proof of QSAC track site insurance.
4. There must be at least two readily accessible dry-chemical "BC" fire extinguishers of not less than 1 gal. capacity, located at each end of the hot-pits.
5. The track perimeter will have a minimum 3-foot high retaining wall or barrier capable of stopping the cars without penetration. Spectators must be kept at least 4 feet behind this 3-foot wall.
6. The entrance and exit from the track must be protected to prevent cars from inadvertently leaving the racing surface in the direction of the pit or spectator areas.
7. Tracks must have a pit lane, separated and protected from the racing surface, for car service.
8. It is highly recommended that a catch fence be placed atop the "pit-wall" using fence fabric capable of rejecting a 1/4 scale car and that the "catch-fence" be a total of at least three feet including the pit-wall itself.
9. Tracks may be asphalt, concrete or dirt but must be free of standing water or debris that may be injurious if thrown by the cars.
10. No alcohol will be allowed in the race area during racing activities. "Racing activities" are defined to include the awards ceremonies.
11. Spectator areas may allow alcohol only if that area is strictly separated from the track and pit areas. Any driver or pit crew drinking alcohol during racing activities will be disqualified. Repeated offenses will result in loss of membership.
12. Only QSAC members may enter the "Hot Pit" or racing areas during race activities. A "Hot Pit" area is any location or area where a car's engine may be started while on ground. The "Hot Pit" must be separated from the "Working Pit" by a 3-foot fence or wall. QSAC card must be carried and displayed.
13. There will be no smoking allowed in the "Hot Pit" area.
14. Firearms are specifically prohibited on any person during any QSAC event.
15. No one will be allowed inside the 3-foot retaining wall while the cars are under the green flag. Pit crew or turn marshals may enter only after the yellow flag is displayed and the cars have slowed to idle or stopped.
16. QSAC encourages that a carburetor return-spring be utilized to force throttle-closure in the event of certain electrical or electronics failures.
17. No car will be permitted on the track with a leaking fuel system.
18. Refueling containers will be closable and marked to alert others of their contents.
19. All races will require a flagman and an assistant who will see that all drivers, pit crew and spectators are safely positioned while the cars are on the track.
20. The race activities must always display the maximum safety for spectators, drivers, officials, etc.
21. Members and/or tracks that fail to abide by or violate QSAC insurance policy guidelines, may face disqualification and/or suspension of membership or track sanction. The appropriate penalty will be determined by the QSAC Co-Chairs.



GENERAL REQUIREMENTS (11.12.06)

1. The race format, program of events and types of cars will be the race organizer's responsibility.
2. All QSAC sanctioned and insured events should follow the QSAC format.
3. All drivers must register for the event prior to operating a car, giving officials the radio frequency he/she will be using. Any changes in frequency must be reported to officials immediately.
4. Any car not slowing for the yellow flag may be placed at the rear of the pack, or in the case of repeat offenses, black flagged and removed from the track for the duration of that race.
5. Disabled cars will be taken off the track for repair. No repair work will be allowed on the track or infield while the cars are running, except for the replacement of a lost wing or dislodged drive belt.
6. QSAC or track official may deem a car or driver a hazard and order the car retired from the race.
7. Cars may only be driven from the designated driver area.
8. No driver may leave the driver's stand to retrieve a disabled car from the track surface. Only pit crew or track personnel may retrieve disabled cars.
9. All cars must have an operational clutch and brake that will allow the car to stop with the engine running and proceed when requested by tech officials.
10. Before the start of the race, all cars will be required to do a brake check at the end of pit road before they enter the racing surface. Cars without brakes will not be allowed to race. (11.12.05)
11. All cars shall front and rear bumpers. See Class rules. Any bumper considered being a hazard by tech officials should be corrected before said car shall compete. (11.12.06)
12. No aircraft frequencies will be permitted.
13. Radios or modules that use 2.4 ghz frequencies will be permitted. Telemetry modules will not be permitted. The Spectrum Lap Timing System is legal. (11.12.06)
14. A frequency control board will be in use at all events with a removable clip for each available frequency. It is strongly recommended that the driver using the frequency, replace the frequency clip with one that has their name on it. (11.12.05)
15. Any driver racing or working on a car (with his/her radio "on") must have the appropriate frequency clip attached to the radio antenna. No transmitters will be "on" without the clip attached. Failure to comply may result in disqualification.
16. Radio frequencies of each participant will be posted to alert drivers and officials of frequency conflicts.
17. Radio impounds may be implemented at the race organizer's discretion. The impounding of radios will be optional at all Region, District, and National Championship Events.
18. Personal transponder mounting location. Transponder should be mounted as low as possible in the car. The transponder must be mounted behind the centerline of the front wheels and in front of the engine. The preferred location is just behind the centerline of the front wheels, but because all cars are not configured the same, there is a tolerance built in the rule. (11.12.05)

TRACK SANCTIONING AND CONSTRUCTION REQUIREMENTS (11.12.05)

1. Track must at all times follow all SAFETY REQUIREMENTS set forth by QSAC.
2. Track must be operated in a manner that is considered fair and equitable within reason at all times.
3. Track must also operate in a manner that is conducive to a family atmosphere.
4. Track must agree to operate under QSAC rules at all QSAC sanctioned Region, District, or National events. There is no allowance for rule deviation unless authorized by an Area Director, Region Director, District Director, QSAC Competition Committee Chairman, or QSAC Co-Chair.
5. If more than four written complaints by current QSAC members are received in one year concerning a particular track, then that track will come under review by QSAC Competition committee and may lose sanctioning and forfeit all fees paid.
6. QSAC reserves the right to cancel sanctioning at any time, but must be by a majority vote from the QSAC Committee Chairmen.
7. Track must submit photos of safety measures to be reviewed by the Competition Committee Chairman when applying for sanctioning.
8. For tracks that are built with a temporary retaining wall, (parking lot), if the track is under 200 feet around measured on inside of the track, then 24 inches is sufficient height for the wall. If track is over 200 feet, then 36 inches is required.
9. It is strongly recommended that each track provide a fenced extension to the top of the pit-wall for the protection of the crews in the hot-pit. Such extension should bring the total height of the pit wall to at least 3 ft.
10. Tracks may be asphalt, concrete or dirt and the configuration may be road course or oval.
11. Tracks must have a pit lane, separated and protected from the racing surface, for car service.
12. The track sanctioning fee per year is \$80.00. For single day events the track sanctioning fee is \$50.00. Note: the single day event fee does not apply towards District , National, or N.C.S. events. (11.12.05)
13. Sanctioning requires pictures of track and surrounding grounds and written description of fencing and safety equipment.
14. All tracks or facilities **MUST** have it's own sanction purchased by April 1st of the current year if you want to be considered for a NCS race for the following year. (Excluding new tracks, New owners, or act of God)

Distribution of Funds

The host track will receive 80% and QSAC will receive 20%. All host tracks at district and national events will be required to provide Plaques or Trophies for the top 3 in the "A" main and in each QSAC sanctioned class.

The Concourse award will be presented to each QSAC Sanctioned class in the form of a Plaque, trophy or other award by the host track.

RACE DAY SCHEDULE OF EVENTS

QSAC sanctioned oval track races should follow the official race format outlined below to insure consistent and safe racing throughout the country. Major deviations from this format must be cleared with QSAC with respect to safety.

Local events, that is, non-Championship or Regional events that do not expect to draw competitors from other areas or regions may deviate from the format and general rules, but in no case are any deviations from defined Safety Requirements acceptable. Failure to comply with the Safety Requirements may lead to cancellation of track sanction and insurance.

Race-day schedule of events

1. Sign In and Registration
2. Practice
3. Driver's Meeting
4. Concourse
5. Pre-Race Tech Inspection
6. Pill Draw or Single Car Qualifying
7. Trophy Dashes (optional)
8. Heat Races
9. Main Events
10. Post Race Tech Inspection
11. Awards

1. **Sign in and Registration** - All competitors must sign in and register to show proof of QSAC membership and insurance before they are allowed on the track. Membership Card must be worn in plain sight at all times during the event.

2. **Practice** - "Controlled" practice must be available on race day to all the drivers and cars in the day's program. Each class of cars will be allowed to practice for a specific length of time (approximately 15 - 20 minutes) then alternated with another class. At least 2 rotations of practice is advised and more if time permits. No more than 10 cars on the track at a time. Each driver may return to the track as many times as he or she wish within a session provided they don't prevent others from equal track time. Each car and driver practicing must have signed up and paid their entry fee prior to race day practice.

3. **Driver's Meeting** - Prior to each day's events, the track officials shall conduct a meeting of drivers and pit crews for explanation and discussion of the day's events, local ground rules, specific event regulations and rules clarifications. All drivers, their pit crews and race officials are required to attend. It is each driver's responsibility to see that he and his crew are present. Failure to comply may result in penalty to the driver.

4. **Concourse** - Concourse is the judging and awarding of the best appearing car in each class. It will be based upon authenticity, beauty and color, cleanliness, design and attention to detail. Judging will be the responsibility of the race promoter or his designate. Concourse bodies need not be raced, but each body is eligible to win one Concourse competition only.

5. **Pre-race Tech Inspection** - At all Region Point-Series, Region Championship, District and National events, all cars must go through a pre-race tech inspection to insure compliance to QSAC rules and technical specifications. Each car will be weighed, measured and visually scrutinized for compliance prior to taking the track. Each car-passing tech will receive a sticker. No car will race without tech sticker. Any car not in compliance with the rules will be given ample opportunity to correct the problem.

Note: It is suggested that pre-race tech inspection be used at local/weekly events on a periodic basis to insure rules compliance.



6. Pill Draw or Single Car Qualifying (11.12.05)

Local tracks and clubs may decide to use either qualifying method and may determine how the heat races will start, either straight-up or inverted.

Pill Draw - The track owner/promoter must provide a Pill-Draw capability consisting of a set of "pills" numbering at least 1-50. Draw per class must include only the number of pills to equal the number of cars entered in the class. (i.e.: 20 GN's = pills 1-20 for draw) . In addition, at weekly races, track officials may choose to use the "Computer-Scramble" option available in some computer-scoring systems.

Single Car Qualifying - Each car will be given 1 warm-up lap and 4 timed laps. The fastest lap of the four will be its qualifying time for the day and will be used to position it for the heat races. Each car will qualify in the order posted by the officials. If a car misses its qualifying order either by choice or other wise, it will fall to the rear of the line in its class and will be given only 2 qualifying laps. A driver may "wave off" a qualifying attempt provided his car does not cross the start/finish line on its first timed lap. Only 2 laps will then be allowed on the second attempt after the others in the class have qualified. If a "racing accident" occurs prior to completing one timed lap and the car cannot continue - 2 laps will be allowed. If the accident occurs after the second lap, the qualification is considered completed. At least one warm up lap must be allowed before a car goes on the clock. The qualifier must race the car he/she qualified with. **Note:** For all of the QSAC Show-down N.C.S. Races it will be mandatory to run single car qualifying and to invert the heats, unless a rainout situation occurs.

7. **Trophy Dashes** - Should the race promoter elect to hold trophy dashes, they will consist of the four fastest cars in each class started inverted - fastest cars in the rear. Race duration may be up to 10 laps.

8. **Heat Races** - Heat races will be lined up according to class and by each car's pill draw position or qualifying time as in the following example 24 car field:

Pill Draw - (24 cars should be run in four 6-car heats)				
Start Pos	Heat #1	Heat #2	Heat #3	Heat #4
1	Fastest Qualifier	2nd Qualifier	3 rd Qualifier	4 th Qualifier
2	5 th	6 th	7 th	8 th
3	9 th	10 th	11 th	12 th
4	13 th	14 th	15 th	16 th
5	17 th	18 th	19 th	20 th
6	21 st	22 nd	23 rd	24 th

Each heat race round of a specific class must be run off before the next class's heats. The sequence will be Sprint Cars, Super-Modifieds, Novice, Super Truck, Sportsman, Grand National.

Heat race duration may be	
Open Wheel Cars	15-35 Laps
Novice Stock Car	15-35 Laps
Super Truck	30-50 Laps
Sportsman Stock Car	30-50 Laps
Grand National Car	30-50 Laps

9. Main Event (11.12.05)

A maximum of 10 cars will make up each main event.

The top 6 qualifying cars will automatically transfer into the "A" Main. The remaining cars will be placed into the lower mains based on qualifying results.

The top 4 cars from the lowest main's results will "bump" into the next main. The top 4 cars from the results of that main will then "bump" into the next main and so on through to the "B" main.

The top 4 finishers from the "B" main will make up starting positions 7 through 10 in the "A" Main.

It is the promoter's option at local and regional races to run one to three rounds of qualifying heat races. Showdown N.C.S. District Races will run 2 rounds of heats. "The Final Showdown" N.C.S. Race will run 4 rounds of heats. If only one round of heat races is used because of weather, the cars transfer into the mains according to their finish from that heat race.

The number of heat race transfers to each main event is dependent on the number of heat races run. For example, if 14 cars are entered, two heat races of 7 cars each would be run. The top 3 cars from each of the 2 heats would transfer into the "A" Main. The remaining 8 cars would run in the "B" main with the top 4 finishers "bumping" into the "A" Main.

If more than one round of qualifying is run, a point system where first place earns 1 point, second place earns 2 points, third place earns 3 points and so on would be used. The six drivers scoring the least points would automatically transfer into the "A" Main with the driver with the lowest total score winning the pole position. Ties in points would be decided by qualifying times (or pill draw if used).

The following charts outline the number of laps for the various classes and mains.

Main Event Duration (Local & Regional Races)			
	A-MAIN	B-MAIN	C-MAIN & DOWN
Sprint	35 Laps	20 Laps	15 Laps
Super Modified	35 Laps	20 Laps	15 Laps
Novice	75 Laps	40 Laps	30 Laps
Super Truck	100 Laps	40 Laps	30 Laps
Sportsman	100 Laps	50 Laps	30 Laps
Grand National	150 Laps	75 Laps	30 Laps

10. Post Race Tech Inspection (11.12.05)—At all Region point series races, Region Championship races, District and National events, the top four A-Main finishing cars must be impounded and the top three must complete the post race tech inspection before the race results can be made final. The fourth place car will be an alternate should one of the others be disqualified. In the event, that all four impounded cars are disqualified, the fifth place car will be declared the winner.

At the completion of each "A" Main, all the finishing cars must be stopped and remain on the track until the results are announced. The drivers or pit crew will be allowed to shut off the engines but no other work is allowed.

The top four cars will be removed by the officials to a guarded impound where the top three cars will be re-weighed, re-measured, and carefully checked for rules infraction.

In addition, one engine will be checked using the properly calibrated and certified instruments. Each engine must be checked also for: visible signs of modification, carburetor bore size and carburetor-mounting block bore size. During a District, National, or N.C.S. Race, a post race technical inspection of a car and engine from each class shall be mandatory. Such inspection shall include measuring port heights, the cylinders will be removed and inspected, the crankcases split and inspected internally, and all other stipulations of the particular class. Upon completion of each "A" Main, the top four finishing cars in each class will be immediately impounded by the National Tech Director or QSAC Tech Inspection Supervisor. The Tech Director or Supervisor will administer a random draw of one of the top three cars to deter-

mine who will under go inspection. The driver or his designate must perform all disassembly work. The track must provide an adequate setting for the post race technical inspection. In the event that post race inspection finds a participant to be outside the rules, another of the top four cars will be chose for inspection. QSAC is not responsible for replacing gaskets or seals of engines that are tore down. It is the racers responsibility.

Any car found to be illegal would be disqualified from the event relinquishing any prize and/or points awards.

The QSAC Tech Inspection supervisor will impound any part of any engine found to be illegal due to the addition or removal of material. An engine found to be altered, even though it may measure legal, will be disqualified and the altered parts will be confiscated and destroyed.

Examples: Cylinders with polished and/or enlarged and/or repositioned intake, exhaust, or transfer ports, sand or bead-blasted surfaces, or machined base, machined crankcases, altered or lightened flywheels, enlarged carburetor or mounting block bores etc.

Note: It is suggested that post race tech inspection be used at local/weekly races on a periodic basis to ensure rules compliance.

11. Awards (11.12.05) - Following tech inspection, the race results will be declared official and the awards will be given out. Awards may be any or all of the following:

Local, weekly, and/or series races may award points, cash, trophies, or non-cash prizes but must award points according to the QSAC schedule. Region point series, Region championship races, District and National races must be advised to QSAC and the dates cleared by QSAC. Promoters will not be required to commit to a guaranteed (beyond an entry fee payout) purse.

It will be left up to the promoter if they wish to have trophies/awards and/or a cash purse for Region Championship events. Region Championships are to be promoted primarily for the benefit of the racers who have supported the races at tracks within their respective Region, whether Region Series Races or the weekly events at their local tracks. To qualify as a bona-fide Region Championship, such events should be scheduled near the conclusion of the regular racing season, (i.e.:) the fall of the year.

Trophies or Plaques, Cash Awards or Non-Cash Awards, Points			
Cash awards will follow the QSAC payout schedule.			
Point's awards will follow the QSAC Point Allocation System			
Finishing Pos	Points	Finishing Pos	Points
1	200	11	160
2	196	12	156
3	192	13	152
4	188	14	148
5	184	15	144
6	180	16	140
7	176	17	136
8	172	18	132
9	168	19	128
10	164	20	124

Note: No participation points will be awarded for the QSAC Showdown N.C.S. Races.

RACE FORMATS - PROCEDURES

1. Standardized Entry Fees

Following entry fees will apply to QSAC sanctioned races:

\$10.00—\$20.00	Local—Weekly Races
1st Car—\$40.00 or Less	Region Point Series Races
1st Car—\$40.00 or Less	Regional Championship
1st Car—\$50.00 or Less	Special National Events
*See Table Below For Fees	District , National & N.C.S. Events

Class	Entry Fee	Fuel Fee
Sprint Car	\$40	\$5
Provisional Class	\$40	\$10
Super Truck	\$45	\$10
Sportsman	\$45	\$10
Grand National	\$50	\$10
No Discount Given For Second Class		*Fuel Fees May Vary*

2. Flagman and Race Starts (11.12.05)

- Each race will have a flagman and/or race director who will control the race events. He must have an assistant to help spot problems around the track and assist in car lineups, frequency problems, etc.
- The flagman and assistant will pre-align the cars for each race in their starting positions on pit road and are responsible that no frequency problems exist. All cars must perform a brake check at the end of pit road before being allowed to enter the track.
- The cars will be allowed five warm up laps before each race to warm up tires, engines, etc. After warm up, the flagman will yellow flag the cars to line up single file or in two lines, (promoter option) in the race lineup, at a slow pace. When the cars are properly aligned, the green flag will be flown as the cars come off turn four.
- The flagman must also use a whistle or horn as an audio signal to the drivers of any change in flag situations.
- There will be no inside passing after the green flag is displayed on starts until the cars have crossed the start/finish line. Violation will result in the immediate display of the yellow flag, and the violator will be placed at the back of the field. Tracks opting for double file starts must allow position leeway between the two car lanes at the green flag. It is the flagman's discretion if it was a clean start or not.

3. Yellow Flag (11.22.07)

- The flagman will fly the yellow flag and use the audio signal for any car stopped on the track infield or outside perimeter of the track after allowing sufficient time for the car to resume under it's own power. He should refrain from yellows if the car can continue. If a car is pointed in the wrong direction on the track, the flagman should automatically yellow flag the race.
- The driver of a car who goes to the infield by choice must indicate to the flagman if he wants a yellow or not.
- Cars involved in yellow flag situations and who require attention on the track to continue must go to the rear of the field.
- Cars requiring repair during yellows must be taken to the pit lane for work. No work is allowed on the track except for replacement of wings or dislodged drive belt, in which case the car goes to the rear of the field.
- It can be an option to count all yellow laps and allow cars to enter under a green flag conditions.
- Yellow flag situations will be a minimum 2 laps or at flagman's discretion starting with first incident, with no passing under yellow.
- A one (1) lap penalty will be assessed for passing under yellow. All cars must hold their position behind the leader as designated by the flagman.



- Any car causing three (3) yellow-flags in any one race may be black-flagged.

- The leader and all cars must slow to a speed that satisfies the flagman. Any car not slowing will go to the rear.
- When the yellow flag appears, the track is yellow all around -no racing back to the start/finish.
- The flagman must allow yellow flag cars sufficient time to catch up to the rear of the field. If a car is not able to catch up or wishes to be passed during yellow to prevent danger to other drivers, the driver must pull to the infield side of the back straight to indicate to the flagman and fellow drivers his situation.
- In the case of a caution, all cars involved will drop to the rear of the field with the car causing the incident following the other cars involved. Drivers not obeying the flagman or race director can be penalized 1 lap. You will receive one (1) warning to move to the rear of the field.
- If an incident occurs during slow laps after a yellow, any cars involved are to be returned to the track position they occupied prior to the incident.

4. Restarts

- All restarts will be single file starts. Passing will be allowed on either side under a "Restart" condition.

5. Checkered Flag

- A race will be considered completed at the moment the checkered flag is displayed or at the moment the scheduled distance is completed by any car, whichever occurs first.
- All running cars must cross the start/finish line on their lap following the checkered for the race to be properly scored.
- Cars not completing the scheduled distance will be ranked in order by total laps completed and the sequence of the finish.
- When any race finish order cannot be determined, the track officials will determine the finish. Their decision is final.

6. Black Flag

- The flagman will use a black flag only if in his/her opinion a car is creating undue hazard on the track.
- The black flagged car must go to the pits until the hazard is resolved.

7. Pit Stops - Refueling - Red Flag Stops (11.12.05)

Red Flag Stops

- Drivers can pit anytime under green flag conditions.
- Refueling shall be accomplished at 50 or 75 lap intervals (depending on track size) under a combination red/yellow-flag condition in all classes. On the 49th or 74th lap, a red/yellow flag shall be displayed indicating the refueling-stop. All cars will assemble behind the leader and enter the pits in this order. After a 20 second pause during which all cars are refueled, the cars will exit pit-lane and when all cars are clear, the green flag will be thrown when the leader is exiting turn four. Note: Any car requiring repairs during a pit stop, must be removed from the pit lane. In the case of Red Flag pit/fuel stops, the car requiring repairs will be pulled from the order in which it entered the pit lane and returned at the back of the field.

- QSAC Showdown N.C.S. Races will have mandatory red flag stops.
- Local tracks and clubs may decide to run green flag stops.

8. Driver and Pit Crew

- Only drivers competing in the specific heat race or main event currently on the track are permitted on the drivers stand. Each driver is limited to one pit person in the hot pit area. A crew member may leave the hot pit area and enter the drivers stand to communicate with the driver for a maximum of three laps and a maximum of two occurrences during the specific heat race or main event.
- Inside the final ten laps of the heat race or main event, **PAGE 10** no crew member is allowed to enter the driver's stand,

regardless of the circumstance.

- Two-way radio communication between a driver and crew is NOT permitted in any class.

9. Un-sportsmanlike Conduct

The following actions are considered un-sportsmanlike and will be dealt with in a manner consistent with the policies set forth below.

- Deliberate destructive action on the track during a practice session or race.
- Physical abuse of another competitor, pit person, or Race Official.
- Excessive and continuous verbal abuse of another competitor, pit person, or Race Official.

District, Region, or Area Director are empowered to disqualify, at his/her discretion, any competitor guilty of one or more of these infractions. The incident shall be reported to the QSAC board, which will determine if further action should be taken. Depending upon the severity of the infraction, remedies including racing eligibility suspension and/or membership revocation could result.

10. Protests

- In the event it becomes necessary, a competitor has the right to submit a protest. If a protest is submitted, it must clearly and specifically state what is being protested, referencing the applicable rule

(s) being violated. Only those issues specifically protested will be inspected or investigated. In the event that a violation is inadvertently discovered during the inspection process that is not identified specifically by the submitted protest, it will be noted, however no penalty would be assessed.

- A protest fee of \$25.00 (cash) shall be applicable to each protest submitted. If the ruling is in favor of the protest, the fee will be returned to the protestor. If the ruling is unfavorable, the fee will be forfeited to the host club. In the event of an unfavorable ruling regarding the disassembly of a motor or carburetor, the fee will be forfeited to the protested competitor to offset the cost of re-assembly of his or her equipment.
- Only a driver in the specific heat race or main event in which the violation or infraction occurred may submit a protest. The written protest, including the cash fee, must be submitted to the Chairman of the Protest Committee, Race Director, or ranking QSAC official present, within ten minutes of the conclusion of the heat race or main event in question. If the specific protest may impact the competitors involved in the next scheduled heat race or main event, that heat race or main event shall be delayed until the protest is ruled on.
- In establishing the penalty for a favorable protest ruling, the nature and intent of the infraction and the degree of competitive advantage will be taken into consideration. Penalties may range from a warning to disqualification from the event. Protest rulings are considered final.

ENGINE AND CARBURETOR MODIFICATIONS (11.12.05)

In the pictures to the right (highlighted by the white arrows) are the only two places that you are allowed to modify the engine in order for the carburetor / phenolic block to fit properly.

For cars that utilize a flat engine plate on the bottom of the chassis for engine mounting, simply shimming the engine, or modifying the plate, will ensure that your engine will fit properly. Any modifications to the engine itself in this regard are not allowed.

Some WYL carburetors (for use in the Sportsman class), have modifications that must be made to make them usable. There is a small brass ball glued into the top of the carburetor or a plastic piece blocking access to the mixture valve. The easiest way to remove this ball or plastic is to carefully drill it out and remove it's remains.

The WYL carburetors may also remove the cone shape spring shown in the picture below.

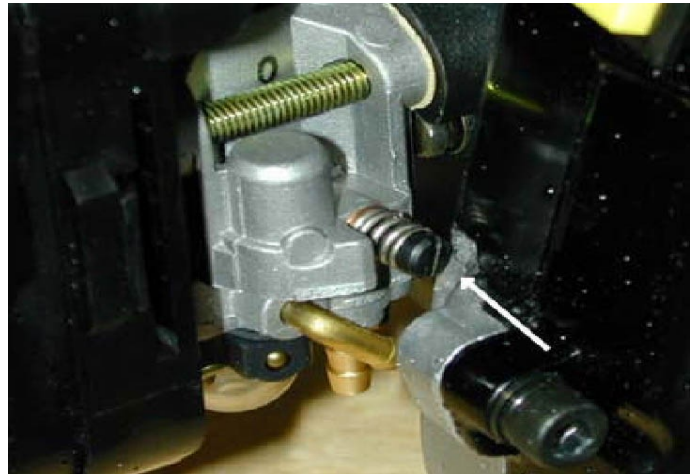

QSAC Showdown N.C.S.

April 15th – 16th Lakeside Speedway (Eastern District Race #1)
May 13th – 14th Machesney Park (Central District Race #1)
June 10th – 11th Dallas Fort Worth (Western District Race #1)
July 15th – 16th Freddies Hobbies (Eastern District Race #2)
August 19th – 20th Indy Quarter Scale Racers (Central District Race #2)
September 23rd – 24th ... Orange Show Quarter Midget Assc. (Final)
Dirt Oval Nationals Date-... TBA

QSAC Showdown N.C.S.

Here is a summary of the overall program. Locations are chosen by a review of eligible locations with an eye toward suitable facilities and geographical distribution. Event location decisions will be a composite of review by the Co-Chairs and the Chairman of the Competition Committee. Considerable care will be given to the scheduling of the events, and their locations, to insure accessibility to the maximum number of competitors from around the country. All races will be conducted under QSAC Rules. As a prerequisite, all host tracks will be QSAC sanctioned at least 60 days prior to hosting an event. The series will consist of six (6) events, five (5) District Showdown races and one (1) Final Showdown race, scoring your best three (3) finishes for the National Championship Awards. Only competition points will be awarded, no participation points. National Championship classes will be Grand National, Sportsman, Super Truck and Sprint Car. Competition points, cash, merchandise, and gift certificates will be awarded at all four individual events. It is recommended that the host track supply event trophies or plaques for 1st thru 3rd in all classes at each of the four individual events. The host track, if they choose, will be permitted to allow one "local" or provisional class to participate in a QSAC Showdown N.C.S. event on a non-points basis. The class could be Modified, Novice or even a local Grand National. Entry and fuel fees will be per the following schedule:

<u>Class</u>	<u>Entry</u>	<u>Fuel</u>
Sprint Car	\$40	\$5
Provisional Class	\$40	\$10
Super Truck	\$45	\$10
Sportsman	\$45	\$10
Grand National	\$50	\$10

Note: There will be no discount given for a second car. Fuel fees may vary do to regional cost differences.

The fees collected from the entries will be allocated with the host track receiving 80%, QSAC receiving 20%. All fuel fees will be allocated directly to the host track unless other arrangements are made prior to the event.



Any deviations from the standard QSAC Showdown N.C.S. format must be submitted in writing to the Competition Committee for approval. Any and all approved deviations from the standard format must be advertised on the respective Race Flyer.

Any track selected to host an event must provide personnel to man the positions of Race Director, Flagman, Scorer, track fuel distribution, pre-race tech, and post-race tech (assistance), a minimum of two Race Spotters, and have Sign Up personnel. The track must supply an entry form for sign up, tech stickers, and paint to mark the engines during pre-race tech. Please contact the National Tech Director, Randy Brown @ (517) 641-4452, for QSAC fuel bottles and body height gauges. The Race Director or QSAC Competition Committee Chairman will choose a five (5) person protest committee for the event.

NOTE: It is the responsibility of the Host Track and/or the Race Director to document (make printed copies) of all single car qualifying, heat race, and main event results. The documents must be sent to either of the QSAC Co-Chairs within 2 weeks after an event has concluded. The Co-Chairs may be contacted by phone or e-mail for mailing instructions at the following:

Jeff Davis QSAC Co-Chair

Phone: (864) 580-3846

E-mail: jeffdavis38@hotmail.com

Mike Sadler QSAC CO-Chair

Phone: (214) 542-2325

E-Mail: Mike Sadler madsad62@aol.com

(11.22.08)

All cars and trucks must have a "WWW.QSAC.ORG" decal applied to the upper front windshield. Sprint Cars must have the same decal applied to the front of the upper wing. This is mandatory to receive Showdown Series points and awards for the Event entered.

AWARDS (11.22.07)

Awards for all six (6) of the QSAC Showdown N.C.S. Races:

Bob's motorsports Hard Chargers Award: The top three finishers (all eligible classes) will receive the following **Quarter Scale Motorsports** parts certificates:
1st place \$25.00 ; 2nd place \$15.00 ; 3rd place \$10.00.

JR Quarter Scale Fast Forward Award: A \$50 gift certificate will be awarded in each A main class in Sprint, Sportsman, Truck and Grand National for the most improved racer in the A main.

HRE Motorsports Pole Award: The "A" main pole sitter (for all eligible classes) will receive a \$25.00 **HRE Motorsports** parts certificate.

For "The Final Showdown" Race only:

Bishop Racing Products will be sponsoring the **BRP Showdown Dashes:** the winner of the 25 lap dashes (all eligible classes) will receive a \$100.00 **BRP** parts certificate.
Special thanks to Todd Bishop

QSAC N.C.S. District Format

The general District format of the QSAC Showdown N.C.S. follows the standard QSAC event formats except as noted below. The program at each event must include races for each official QSAC class in which 3 or more cars are present.

- Points will be awarded, as outlined on page 9, for each eligible Class in which at least 3 cars compete. Eligible classes include Grand National, Sportsman, Super Truck and Sprint Car. **Note: You may not run for National Championships in both Grand National and Sportsman classes. (11.12.06)**
- A Concourse for each eligible class with an award (trophy or plaque) for the winner is OPTIONAL. Concourse Bodies need NOT be raced.
- It is required that the host track supply event awards (plaques or trophies) for 1st, 2nd, and 3rd place in all classes.
- For QSAC Showdown N.C.S. races, The 3 highest finishes per competitor will be used to determine their final standing in the National Championship. The top 3 in each class at the end of the series will be awarded trophies or plaques supplied by QSAC. **(11.12.06)**
- The Grand National, Sportsman, Super Truck, and Sprint Car winners at each of the five (5) Western, Eastern, and Central District races will get an automatic entry in the **BRP Showdown Dashes** which are being held at "The Final Showdown" race. One entry per driver. More information will be given about the **BRP Showdown Dashes** on page 16.
- The QSAC Showdown N.C.S. "Western, Eastern, & Central District" Races will have single car qualifying on Friday afternoon at 1:00 pm and two rounds of heat races (with inverted starts). On Saturday there will be controlled practice and the mains.
- In the event single car qualifying cannot be completed on Friday due to weather, a pill draw will be completed (Friday night, after qualifying is suspended). The **Hendershot Pole Awards** will be awarded to the top qualifier (driver with the least amount of heat race points) of the "A" main in each eligible class.
- In the event a driver is not able to participate in the qualifying activities on Friday, he or she will be entered in the heat races for their class, in the last qualifying position (In the order they registered if more than one driver is involved).
- A standard bump-up format utilizing as many lower mains as needed to accommodate all class entries is required.
- In the Sprint Car class, only cars complying with the "Sprint Car"

rules are eligible for competition (Super Modified cars are not eligible).

Single Car Qualifying

- Each car will be given 1 warm-up lap and 4 timed laps. The fastest lap of the four will be its qualifying time for the day and will be used to position it for the heat races. Each car will qualify in the order posted by the officials. If a car misses its qualifying order either by

Following Lap Count minimum format required at each event

Sprint Car	A-Main	75 Laps
	B-Main & Lower	50 Laps
Super Truck	A-Main	200 Laps
	B-Main	100 Laps
	C-Main & Lower	75 Laps
Sportsman Stock Car	A-Main	150 Laps
	B-main	100 Laps
	C-Main & Lower	75 Laps
Grand National Stock Car	A-Main	300 Laps
	B-Main	150 Laps
	C-Main & Lower	75 Laps

Note: "Support Classes" (those not eligible for NCS Points or awards) shall have the opportunity to race, if there are at least three (3) cars in the class with QSAC approval. Heat-races shall be limited to 30 Laps, and A-mains to 100 Laps, (75 laps for Novice Stock-car).

Note: If there are less than 10 entries, the number of laps may be reduced.

choice or other wise, it will fall to the rear of the line in its class and will be given only 2 qualifying laps. A driver may "wave off" a qualifying attempt provided his car does not cross the start/finish line on its first timed lap. Only 2 laps will then be allowed on the second attempt after the others in the class have qualified. If a "racing accident" occurs prior to completing one timed lap and the car cannot continue - 2 laps will be allowed. If the accident occurs after the second lap, the qualification is considered completed. At least one warm up lap must be allowed before a car goes on the clock. The qualifier must race the car he / she qualified with.

Heat Races

- Heat races will be lined up according to class and by each car's qualifying time or pill draw (because of weather) as in the example of a 24 car field found on page 8.
- The five (5) Western, Eastern, and Central District Showdown N.C.S. races will have two heat races two (2) on Friday. **(11.14.09)**

Mains

- A maximum of 10 cars will make up each main event.
- The top 6 qualifying cars will automatically transfer into the "A" Main. The remaining cars will be placed into the lower mains based on qualifying results.
- The top 4 cars from the lowest main's results will "bump" into the next main. The top 4 cars from the results of that main will then "bump" into the next main and so on through to the "B" main.
- The top 4 finishers from the "B" main will make up starting positions 7 through 10 in the "A" Main.
- Showdown N.C.S. District Races will run 2 rounds of heats. "The Final Showdown" N.C.S. Race will run 4 rounds of heats. If only one round of heat races is used because of weather, the cars transfer into the mains according to their finish from that heat race.

- The number of heat race transfers to each main event is dependent on the number of heat races run. For example, if 14 cars are entered, two heat races of 7 cars each would be run. The top 3 cars from each of the 2 heats would transfer into the "A" Main. The remaining 8 cars would run in the "B" main with the top 4 finishers "bumping" into the "A" Main.
- If more than one round of qualifying is run, a point system where first place earns 1 point, second place earns 2 points, third place earns 3 points and so on would be used. The six drivers scoring the least points would automatically transfer into the "A" Main with the driver with the lowest total score winning the pole position. Ties in points would be decided by qualifying times (or pill draw if used).

Initial Race Starts and Re-starts

- On initial race starts, the cars will line up single file and there will be no passing before crossing the start finish line.
- On re-starts, the cars will line up single file and passing on either side is allowable only after the green flag has been displayed.
- It will be the flagman's discretion, to re-start the race with a green, white, & checkered flag, if there are enough laps left in the race.

Yellow Flag

- The flagman will fly the yellow flag and use the audio signal for any car stopped on the track, infield, or outside perimeter of the track after allowing sufficient time for the car to resume under its own power. He should refrain from yellows, if the car can continue. If a car is pointed in the wrong direction on the track, the flagman should immediately yellow flag the race.
- The driver of a car who goes to the infield by choice must indicate to the flagman if he wants a yellow or not.
- Cars involved in yellow flag situations and who require attention on the track to continue must go to the rear of the field.
- In the case of a caution, all cars involved will drop to the rear of the field with the car causing the incident following the other cars involved. Drivers not obeying the flagman or race director can be penalized 1 lap. You will receive one (1) warning to move to the rear of the field.
- If a car is "clearly" spun out after the caution has been displayed, that car will be allowed to retake its position prior to taking the green flag.
- Cars requiring repair during yellows must be taken to the pit lane for work. No work is allowed on the track except for replacement of wings or dislodged drive belt, in which case the car goes to the rear of the field.
- All yellow flag laps will count.
- Yellow flag situations will be a minimum 2 laps or at flagman's discretion starting with first incident, with no passing under yellow.
- A one (1) lap penalty will be assessed for passing under yellow. All cars must hold their position behind the leader as designated by the flagman.

Checkered Flag

- A race will be considered completed at the moment the checkered flag is displayed or at the moment the scheduled distance is completed by any car, whichever occurs first.
- All running cars must cross the start/finish line on their lap following the checkered for the race to be properly scored.
- Cars not completing the scheduled distance will be ranked in order by total laps completed and the sequence of the finish.



- When any race finish order cannot be

determined, the track officials will determine the finish. Their decision is final.

Black Flag

- The flagman will use a black flag only if in his/her opinion a car is creating undue hazard on the track.
- The black flagged car must go to the pits until the hazard is resolved.

Pit / Fuel Stops - Red Flag

- All QSAC Showdown N.C.S. Races will have Red Flag Fuel Stops at 50 or 75 lap intervals depending on the track size.
- Drivers can pit anytime under green flag conditions.
- Refueling shall be accomplished at 50 or 75 lap intervals (depending on track size) under a combination red/yellow-flag condition in all classes. On the 49th or 74th lap, a red/yellow flag shall be displayed indicating the refueling-stop. All cars will assemble behind the leader and enter the pits in this order. After a 20 second pause during which all cars are refueled, the cars will exit pit-lane and when all cars are clear, the green flag will be thrown when the leader is exiting turn four.

Note: Any car requiring repairs during a pit stop, must be removed from the pit lane. In the case of Red Flag pit / fuel stops, the car requiring repairs will be pulled from the order in which it entered the pit lane and returned at the back of the field.

Pre-Race Technical Inspection

- All cars must go thru pre-tech inspections to insure compliance with the QSAC rules and technical specifications for their class. The pre-race tech inspection will consist of visually scrutinizing for rules compliance, weighing the cars / trucks, check spoiler height, check car / truck roof height, check right front tire compound, and marking the engines' screws / bolts with paint. Only one body will be inspected. Each car passing tech will receive a sticker. No car will race without a tech sticker. Any car not in compliance with the rules will be given ample opportunity to correct the problem.
- After an engine has been painted, you may not open it up or change an engine. If for some reason, a driver needs to replace their engine, the new and old engine must be taken to the Tech Director to be marked with paint. The engine being replaced may be subject to being tore down if the Tech Director, Race Director, or a QSAC Official deems it is necessary.

Post-Race Technical Inspection

- A post race technical inspection of a car and engine from each class shall be mandatory. Such inspection shall include measuring port heights, and all other stipulations of the particular class. Upon completion of each "A" main, the top four finishing cars in each class will be immediately impounded by the Tech Director.

The Tech Director will administer a random draw of one of the top three cars to determine who will under go inspection. The track must provide an adequate setting for the post race technical inspection.

- In the event that post-race inspection finds a participant to be outside the rules, another of the top four cars will be chosen for inspection. In the event, that all four impounded cars are found to be illegal, then the fifth place car will be deemed the winner. The National Tech Director, QSAC Competition Committee

Chairman, and the QSAC Co-Chairs will determine how far an engine will be tore down for inspection.

- **DISQUALIFICATION:** If a driver is disqualified from an event, the event that the disqualification occurred in, must be scored in that driver's series total and not used as a "drop".

Drivers and Pit Crews

- Only drivers competing in the specific heat race or main event currently on the track are permitted on the drivers stand. Each driver is limited to one pit person in the hot pit area. A crew member may leave the hot pit area and enter the drivers stand to communicate with the driver for a maximum of three laps and a maximum of two occurrences during the specific heat race or main event.
- Inside the final ten laps of the heat race or main event, no crew member is allowed to enter the driver's stand, regardless of the circumstance.
- Two-way radio communication between a driver and crew is NOT permitted in any class.

Un-Sportsmanlike Conduct

The following actions are considered un-sportsmanlike and will be dealt with in a manner consistent with the policies set forth below.

- Deliberate destructive action on the track during a practice session or race.
- Physical abuse of another competitor, pit person, or Race Official.
- Excessive and continuous verbal abuse of another competitor, pit person, or Race Official.

District, Region, or Area Director are empowered to disqualify, at his/her discretion, any competitor guilty of one or more of these infractions. The incident shall be reported to the QSAC board, which will determine if further action should be taken. Depending upon the severity of the infraction, remedies including racing eligibility suspension and / or membership revocation could result.

Protests

- In the event it becomes necessary, a competitor has the right to submit a protest. If a protest is submitted, it must clearly and specifically state what is being protested, referencing the applicable rule (s) being violated. Only those issues specifically protested will be inspected or investigated. In the event that a violation is inadvertently discovered during the inspection process that is not identified specifically by the submitted protest, it will be noted, however no penalty would be assessed.
- A protest fee of \$25.00 (cash) shall be applicable to each protest submitted. If the ruling is in favor of the protest, the fee will be returned to the protestor. If the ruling is unfavorable, the fee will be forfeited to the host club. In the event of an unfavorable ruling regarding the disassembly of a motor or carburetor, the fee will be forfeited to the protested competitor to offset the cost of re-assembly of his or her equipment.
- Only a driver in the specific heat race or main event in which the violation or infraction occurred may submit a protest. The written protest, including the cash fee, must be submitted to the Chairman of the Protest Committee, Race Director, or ranking QSAC official present, within ten minutes of the conclusion of the heat race or main event in question. If the specific protest may impact the competitors involved in the next scheduled heat race or main event, that heat race or main event shall be delayed until the protest is ruled on.
- In establishing the penalty for a favorable protest ruling, the nature and intent of the infraction and the degree of competitive advantage will be taken into consideration. Penalties may range from a warning to disqualification from the event. Protest rulings are considered final.

BACKUP CAR, BODY, or ENGINE

- In the case of a competitor's car or body becoming irreparably (as judged by QSAC official) damaged during practice, a heat, or lower-main, a "substitute" car or body may be used to finish the event.
- In either, the case of a car and/or body being substituted, it should

be understood that should it make the "A" main, the "substituted" car and/or body will be subject to a combination pre/post-race technical inspection to insure its total compliance with the rules following the conclusion of the event.

- Any "substitute" car, body, and/or engine shall start at the rear of the next race it has qualified for.
- The source of the "substitute" car may be the competitor's spare, borrowed from a friend, or purchased on the spot.

TRACK FUEL (11.22.07)

- All competitors will be required to use a pre-mixed, host-track provided fuel.
- The fuel specified is VP (brand) C-16 or C-12, mixed with 2 ounces of AmsOil Saber 2-stroke oil per gallon. QSAC recommends that the host track buy fuel in 5 gallon containers. This will allow unused fuel to be sold in 5 gallon increments to participants after the racing event is completed.
- A fuel fee, paid at time of sign-up will be \$10.00 for all classes except Sprint Cars which will be \$5.00. Fuel fees may vary due to regional cost differences.
- Fuel distribution shall be the responsibility of the host track / club / promoters.
- Competitors will be able to fuel their cars only in the hot-pit, using fuel-bottles provided.
- QSAC fuel bottles are available by contacting the National Tech Director, Randy Brown @ (517) 641-4452

SCORING TIE BREAKER RULE

- If the situation occurs that there is a N.C.S. point total tie in any class or finishing position, the following tie breaker (s) will be used in sequence until the tie is broken. (Please note that only the three races being scored in the overall series results are considered in the tie breaking process).
 1. The competitor with the most 1st place finishes would prevail.
 2. If the tie remains, the competitor with the most 2nd place finishes would prevail and so on until the tie is broken.
- If after consideration of the series race results, a tie remains, QSAC will default to the starting lineup based off of the heat race results for the scored "A" mains. **(11.12.06)**
 1. Mains (scored is defined as the three races used by each competitor for the series total).
 2. The competitor with the most "Pole" positions would prevail.
 3. If the tie remains, the person with the most 2nd place starts would prevail and so on until the tie is broken.
- If a tie still remains, dual awards will be issued by QSAC.

RAIN OUT RULE

- The host track will make every attempt to complete the event on Saturday. If the event is delayed due to weather, the schedule will resume on Sunday, starting at the point the event was interrupted.
- If the event cannot be completed on Sunday, the rain out format will be used, and points awarded as follows:
 1. If qualifying is done by Pill Draw, heat races must be completed before points can be awarded.
 2. If no qualifying or heat races have been completed, the event is cancelled and all entrants will be awarded 5 participation points.
 3. If only single car qualifying has been completed, points will be awarded based on qualifying results.

4. If only heat races are completed and NO mains are started, points will be awarded based on heat race results.
5. If the mains have started, those mains completed will be scored according to the results. If a main is red flagged prior to reaching the half way point, it will be scored as qualified. If the main is beyond the half way point, it will be considered complete and scored based on the positions at the time of the red flag. If the remaining event is subsequently cancelled, all remaining mains will be scored as qualified.

=====

=====

“THE FINAL SHOWDOWN” FORMAT

The general format of the QSAC Showdown N.C.S. “The Final Showdown” Race follows the standard QSAC event formats and the District format except as noted below.

- The QSAC Showdown N.C.S. “The Final Showdown” Race will have single car qualifying on Friday at 11:30 AM and compete in two heat races (the starts will be inverted).
- Friday night, after qualifying and the first three rounds of heat races are over, the **BRP Showdown Dashes** will begin. The class order will be Sprint Cars, Super Truck, Sportsman, and Grand National. The dashes will have eight (8) cars and will be 15 laps long. The top five cars eligible for the dash are the five (5) previous QSAC Showdown N.C.S. District winners from each class, they will line up according to how they qualified for “The Final Showdown” race. The next three positions will be filled by the top three (3) qualifiers of “The Final Showdown” race. If one or more of the previous winners are not present, then we will fill the remaining position (s) with qualifiers 4 thru 8, if needed.
- On Saturday, the fourth round of heat races will be inverted, then the mains.
- The mains will be set by the four (4) rounds of heat races run on Friday and Saturday.



Special Thanks To Our Race Sponsors

Bishop Racing Products (BRP)

Ask for Todd Bishop

(479) 751-6232

E-mail: tbishop44@cox-internet.com

<http://bishopracingproducts.com>

Bobs Motorsports

Bob Lydecker.

Bob: (702) 210-3961

Website: <http://www.bullseye.9f.com>

E-mail: bobsmotorsports@hotmail.com

JR QuarterScale

Fred Miavitz.

Fred: (330) 296-4354

Website: <http://www.freddieshobbies.com>

E-mail: JR.Quarterscale@neo.rr.com

HRE Motorsports

David Hendershot.

David: (866) 951-2112

E-mail: hremotorsports@verizon.net

2011 QSAC Showdown N.C.S.

Who are you shooting for in 2011 ???

Our 2010 QSAC National Champions

Grand National	Jeff Davis
Sportsman	Randy Brown
Sprint Car	DC
Super Truck	Mike Sadler

2011 QSAC Dirt Oval

Sprint Car National Championship Race

TBA

***Congratulations To The
2010 Sprint Car Dirt Oval National Champion: Brian Rainbolt***

This will be the fifth year for this race. We look forward to bringing together all of the hard core Sprint Car owners from across the United States at the beautiful **TBA**. If you own a Sprint Car this is one event you do not want to miss.

- Friday.....practice all day until 5:00PM. The going to a local short track to watch the big cars for free and put on a 1/4 scale display for the patrons.
- Saturday.....Single car qualifying, 2 heats, the mains, and the award presentations.

LOCATION: TBA



QSAC Showdown N.C.S. "District" Races Schedule

Note: This is the tentative schedule of events for the race weekends.

Thursday.....Open Practice

Friday..... Sign up and Pre-Tech at 9:00 am

Open Practice till 10:00 am

Controlled practice (15 minute intervals) 10:00am until 12:00 pm Noon

Line up of all cars on track and Optional Concourse Judging 12:00 pm Noon

Drivers Meeting at 12:00 pm Noon during Concourse Judging

Single Car Qualifying at 1:00 pm

(Class order will be Sprint Car, Super Truck, Sportsman, and Grand National)

Round #1 & #2 Heat Races to start right after qualifying

(Round #2 Heat Races will be inverted)

Open Practice after Round #2 Heat Races

Saturday.....Open practice till 9:00 am

One round of controlled practice at 9:00am

Short Drivers Meeting at 10:00 am

Mains (top 6 locked into the A-Main from the 2 rounds of heats)

Trophies and awards presentation

Bob's Motorsports Hard Chargers Award (Top 3 for Sprint, Sportsman, Truck, and Grand National)

HRE Motorsports Pole Award (Sprint, Sportsman, Truck, and Grand National)

JR Quarterscale Fast Forward Award (Sprint, Sportsman, Truck, and Grand National)



QSAC Showdown N.C.S. “The Final Showdown” Race Schedule

Note: This is the tentative schedule of events for the race weekend.

Wednesday.....Open Practice

Thursday.....Open Practice and Controlled Practice if needed

Friday..... Sign up and Pre-Tech at 9:00 am

Open Practice till 10:00 am

One round of controlled practice (15 minute intervals) at 10:00 am

Line up of all cars on track and Optional Concourse Judging 11:00 am

Drivers Meeting at 11:00 am During Concourse Judging

Single Car Qualifying at 11:30

(Class order will be Sprint Car, Super Truck, Sportsman, and Grand National)

Round #1 Heat Races

Round #2 Heat Races (these races will be inverted)

*Heat races #1 and #2 will be reshuffled for rounds #3 & #4

Round #3 Heat Races (will be shuffled)

15 lap **BRP Showdown Dash** races to begin right after heat race #3

(Class order will be Sprint Car, Super Truck, Sportsman, and Grand National)

(Five District Winners plus Top 3 Single Car Qualifiers to get a field of 8 cars)

Open Practice after dash races

Saturday.....One round of controlled practice (15 minute intervals) at 9:00 am

Short Drivers Meeting at 10:15 am

Round #4 Heat Races (these races will be inverted from round #3)

Mains (top 6 are locked into the A-Main from the 4 rounds of heats)

Trophies and awards presentation

Bob’s Motorsports Hard Chargers Award (Top 3 each class)

HRE Motorsports Pole Awards

JR Quarterscale Fast Forward Awards

BRP Showdown Dash Award

QSAC Showdown N.C.S. Trophies or Plaques (Top 3 each class)

TECHNICAL COMPLIANCE RESPONSIBILITY

It is the responsibility of each driver to insure his/her Quarter-Scale Race car is in total compliance with all applicable QSAC Rules. This means Safety, General and Technical Specifications as defined herein. It is important that each competitor read and understands all of the rules as they apply to safety, race format, driver-conduct, and technical specifications. Ignorance of the Rules is not a defense for violation of them. Failure to comply may result in immediate disqualification, loss of points for the event, and further action as deemed necessary by QSAC.

=====

GENERAL SPECIFICATIONS *(applies to all classes unless otherwise noted in the individual class specifications)*

1. The general specs contained herein shall be enforced for each class except where the class Technical Specifications conflict. In such case the class Technical Specifications shall take precedence.
2. All cars must meet the general specifications, the safety requirements and the technical specifications for its class. Modification (except engine) is permitted within the specifications but will be subject to review and approval by QSAC.
3. Situations may upon occasion arise that are not precisely covered in these rules or procedures. A ruling will be made by the ranking QSAC official present, consistent with previous rulings in situations of similar nature. The ranking QSAC official present shall make interpretations of rules and his/her rulings shall be considered final.
4. All classes are subject to fuel line specifications (line length, size, return and vent lines) as defined in the Grand National Technical Specifications.

ENGINE (11.12.05)

1. Only industrial type, 2-stroke, magneto ignition, 23cc maximum, air cooled, integral starting engines will be allowed. The use of any engine must be approved by the QSAC National Rules Committee 4 weeks before said engine may be raced in any QSAC sanctioned event. No rotary valve, reed valve, or non-integral cylinder head engines allowed.
2. To obtain approval, a minimum of 5 engines must be submitted to QSAC along with factory specifications and technical data pertaining to performance, as well as a supply of gaskets, etc. to facilitate disassembly for inspection and reassembly for testing.
3. Approved engines are as follows: Zenoah G2D-44, 57 (Red Max HT230), Zenoah G2D-70, (all versions) Zenoah G-23RC/G230RC. Kawasaki TF22 (All engines must have factory numbers).
4. There is no engine "Claiming" Rule.
5. Engine replacement parts other than those supplied by the original engine manufacturer will be considered as not-legal parts.
6. Since the supply of OEM crankshaft bearings is questionable, equivalent type bearings will be allowed. The replacement must be a metallic ball bearing, non-shielded or non-sealed. Absolutely no ceramic bearings. We strongly recommend the use of OEM crankshaft bearings and OEM crankshaft seals with springs.
7. Modifications - NONE - no removal or addition of parts or material from engine or from any part of component of engine whether or not performance is enhanced. Media blasting of any portion of the cylinder or internal engine components is not allowed for any purpose. The only exceptions are listed on page 11. The exhaust, carburetor, and clutch are not considered part of the engine and will have their own set of rules.
8. All pre-manufactured gaskets made specifically for the Zenoah engines will be legal. Scratch built gaskets will NOT be legal. Exceptions are noted in item #9.
9. On all engines, any type of gasket sealant, provided it can be easily removed during the tech inspection process without damaging the mating surfaces of the engine components, may be applied to either or both sides of the gasket located between the cylinder and the phenolic intake block. In



addition, on the G230RC engine only, gasket sealant may be applied to either or both sides of the gasket located between the cylinder and crankcase.

EXHAUST (11.12.05)

1. All engines shall have chambered exhaust system that effectively reduce noise. No open exhaust or un-chambered open pipes are allowed. Any car deemed too loud by officials will not race until the problem is corrected. Maximum noise level is 85 DBA 30 feet from the track surface whenever a noise limit is in effect. Noise limits are imposed by local ordinance or at the discretion of the promoter. Certain classes require stock Zenoah Mufflers only. (See appropriate class specifications.)
2. All Classes must use Zenoah Mufflers p/n's T2070-15110, 1751-15101, 1148-15112 unless otherwise noted in the individual class specifications.
3. No spacers or extensions between cylinders exhaust port and muffler.
4. Only one exhaust gasket is permitted.
5. Muffler outlet may not be added to or internally or externally cut.
6. The spark arrester screen mounting tab may be removed.
7. Exhaust may be redirected by use of a piece of 1.00 inch (ID) or larger hose or tube.
8. Any tuned expansion chamber exhaust systems (Open-Wheel only) regardless of material of construction, must meet the QSAC mandated noise level limits as defined in general section #1, (85db at 30ft.) when a noise limit is required by the track owner, promoter, or by local ordinance.

CARBURETOR (11.22.07)

NOTE: All classes to run an 8.5 or 10.5 Restrictor / Adaptor plate. See class rules for further information. The plates will be mandatory at all QSAC sanctioned events for 2008 and beyond. It is strongly recommended that local clubs and tracks adopt this rule as soon as possible. This will make the transition easier for everybody, because sometime during the 2008 season, the supply of our existing blocks will run out and all manufacturers will be forced to ship new cars with the stock Zenoah insulator block PN 1148-13161 and this new plate. QSAC Members and Manufacturers may purchase the plates from Mike Willman for \$8.00 plus shipping. Since this is a mandated part, QSAC Members and Manufacturers will pay the same price.

Purchasing / Contact Information:

Wilmann Racing Products

WWW.WILLMANNRACINGPRODUCTS.COM

Phone: 402-786-5513 AFTER 4:00 P.M. CST

E-Mail: Mwill4x@aol.com

1. Only the Walbro WY-1 Series, (-1, -16, etc), the WYK 32, 51, 61, 194 and the WYL 99, 78, 79, or 115 carburetors are allowed.
2. Carburetor jets may be changed, popet-valve (needle/seat) may be adjusted, popet valve (spring) may be modified and adjusted, but no other modifications are permitted.
3. Both the #34-509 (aluminum barrel) and #34-514 (phenolic barrel) are approved replacement barrel valves for the WY-16 carburetor.
4. Note: It continues to be illegal to modify EITHER side of the Phenolic carburetor block, or to alter the size of the openings in the block.

CLUTCH (11.22.07)

All classes: Clutches must maintain a standard two-shoe, single-spring, centrifugal configuration, with no external adjustment capability. Clutch arbor and bolts/washers may not be removed, modified or lightened. The clutch housing may be lightened or modified for cooling, servo mounting, clutch disassembly, etc. Grand National, Super Truck, & Sprint Classes may use steel or aluminum clutch shoes and shoes may be lightened. Aftermarket clutch springs are allowed. Sportsman Class clutches must remain entirely stock including spring and shoes

IGNITION MODULE

Ignition modules are limited to those supplied with the engine or two aftermarket modules with markings of SIG-01 or EY850 only. All modules must have the factory applied date code.

FUEL (11.22.07)

1. Only pump gasoline and racing gasoline may be used if it is available on a national level Example: Cam-2, VP, Torco, etc.
2. Fuel additives are Strictly prohibited except lubricant.
3. The use of methyl alcohol/methanol is not allowed .

FUEL SYSTEM (11.12.05)

1. All classes will use a maximum 8 oz. capacity fuel tank.
2. All classes are limited to a maximum of 60 inch total fuel line length which includes a maximum of two .125 inch ID x .50 inch OD x 1.25" long fuel filters, fill, feed, return and vent lines. Tubing located inside the primary fuel tank is excluded.
3. The fuel system must be filled and vented on the right side of the car. The car must be fill on the right side due to safety issues and vented on the right side to allow overflow fuel to be discharged toward the pit wall. **(12.19.10)**
4. As an option, a maximum 2oz catch tank may be installed on the primary tank vent line. The catch tank may not have a fuel pick up mechanism.
5. All fuel lines and filler lines must be .125 inch maximum ID.
6. Only one vent line and one filler line permitted.
7. Refilling bottle shall be a 1-quart maximum size. Manual pressurizing only during refilling.

CAR NUMBERS

1. Each car shall be clearly numbered and visible from the scoring stand. Numbers must appear on both sides of the car, except when special scoring numbers are used. Car numbers placed on wings must have additional identification should the wings become detached while racing.
2. Minimum number size is 3.00 inches on the wing and 2.00 inches on the tail tank for open wheel cars. 4.00 inches for full-bodied cars and trucks.

CHASSIS (11.12.05)

1. No shifting or variable speed drive trains permitted.
2. All cars must have 4-wheel suspension.
3. Engines must be mounted with either the spark plug or crankshaft centerline on the car longitudinal centerline of the chassis' main rails with a tolerance of plus or minus .50 inch. Main rails are defined as the major symmetrical load carrying longitudinal frame members, and do not include "side pods" used for body mounts.
4. Differentials permitted in all classes.
5. Two-wheel drive (rear) only.
6. Basic frames must be symmetrical in design.
7. Mainframe rails should be mirror image left to right with minor deviations for component clearance allowed.
8. Suspension components may be modified in material to achieve lighter weight and/or greater strength.
9. No cantilever suspension allowed.
10. Cars must maintain a 50% - 50% weight bias plus or minus a 10% total spread. Thus, the maximum bias left to right is 55% - 45%

TIRES AND WHEELS (11.12.05)

1. Wheels and tires may be substituted and modified within the specific class requirements.
2. Maximum wheel width 3.00 inches, maximum diameter 4.00 inches (at the bead).

3. Wheels must be scale appearing with a maximum offset of 1.00 inch.
4. Wheel knockoffs are not allowed with the exception of the open wheel classes.
5. All wheels must have minimum 2 lugs.
6. All classes shall use tire configurations as follows: A molded foam host mounted on an approved wheel and shall have a rubber outer band or cap. Spikes are allowed for dirt tracks only.
7. No tire cleaners or tire traction treatments permitted. Tires may not be cleaned with any liquid or foam of any kind.
8. Track preparation to improve traction is permitted.
9. Tire circumference (roll-out) is measured as an average of the center and outside edge measurements. This measurement shall be 22.00" maximum and 17.00" minimum (LF, RF, RR) and 16.75" minimum (LR).
10. For open wheel classes, the 17.00" minimum applies only to the right rear tire.
11. Maximum tread width is 3.25 inches, with a minimum tread width of 2.75 inches, and 3.75 inches maximum sidewall width.
12. Competitors in all Stock-Car and Super Truck classes must utilize the QSAC approved right front tire-bands on the competitor's choice of host.
13. Right front tire bands will have a unique (molded into the band) identifier to designate it is an "Approved" tire band.
14. Approved compounds as submitted by the manufacturers with suggested corner locations are as follows:

- **Bishop Racing Products (BRP)**

- Left Front/Left Rear = L10, L20, L30
- Right Rear = 410, 405, C-4. And C-5
- Right Front = 66 or 96 or 96Z

- **WCM Diamondback**

- Left Front/Left Rear = RZ2, ZR, XZR
- Right Rear = M3, M4, Signature
- Right Front = A or B

The above are the ONLY allowable compounds permitted and can ONLY be run where designated (Example: Approved Right Rear compounds on Right Rear Only.) **(11.22.07)**

MISCELLANIOUS (11.12.06)

1. No electric or electronic device may be used in any class unless specified in the Technical Specifications for that class. Examples: rate gyros, moveable ballast, any electronic or electrical adjustment device other than one or two steering and one or two throttle / brake servos.
2. One battery powered tool per pit position is permitted for changing of tires, etc., during a race.
3. On-board tachometers are permitted in all classes.
4. Onboard telemetry is NOT permitted in any class.

IMPACT PARTS (11.12.05)

Impact Parts are defined as parts or components that are uniquely critical to the competitive operation of a quarter scale race car. They are further defined as items where significant technical developments and/or enhancements might possibly render the previous version of the part or component obsolete or non-competitive or represents an excessive cost versus benefit to the racer. The current list of IMPACT PARTS includes but is not limited to, engines, carburetors, clutches, clutch bells and components, brakes and components, shock absorbers, tires, hosts and bands and bodies. Parts or components should be readily available to all QSAC members.

Manufacturers are urged to submit in writing, parts or components that fall into this category, to the Impact Parts Committee Chairman or Co-Chair for review and disposition as to the legality for competition under QSAC rules.

ATTENTION POTENTIAL BODY MANUFACTURERS

If you intend to manufacture a "new" Quarter Scale Race Body (Car or Truck) it is strongly recommended that you contact the QSAC Impact Parts Committee *BEFORE* you begin the project, to insure the final product will be within acceptable parameters for approval for QSAC Competition.

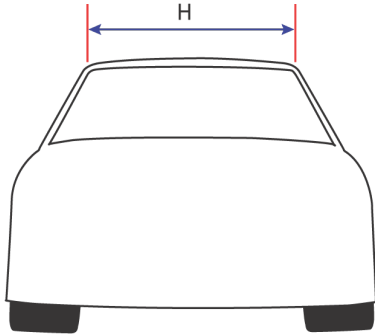
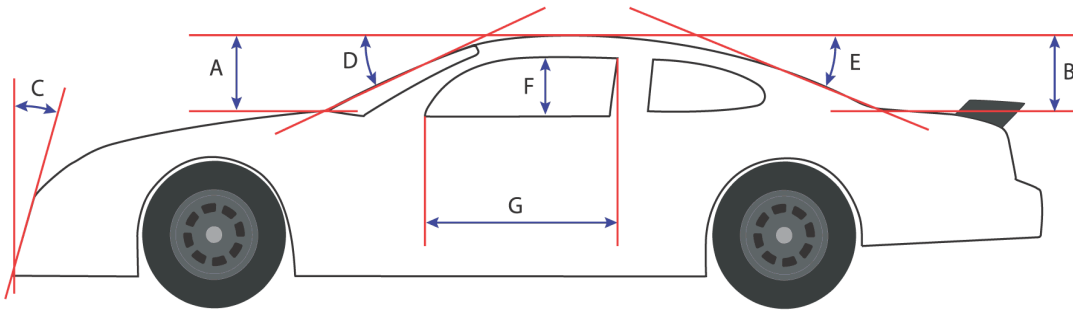

Stock Car Body Dimensions:

- A: Roof height Measured at base of windshield. A+B minimum of 5.50"
- B: Roof height Measured at base of rear window. A+B minimum of 5.50"
- C: Angle of front lower air dam. Maximum of 25 degrees from vertical
- D: Angle of windshield measured at center. Minimum angle of 22 degrees.
- E: Angle of rear window measured at center. Minimum angle of 15 degrees
- F: Height of side windows. "Recommended" minimum of 3.312"
- G: Length of side windows. "Recommended" Minimum of 8.00"
- H: width of roof. Minimum of 11.25"
- I: Overall length: 44.00-49.00"
- J: Overall width: 17.50-19.50"

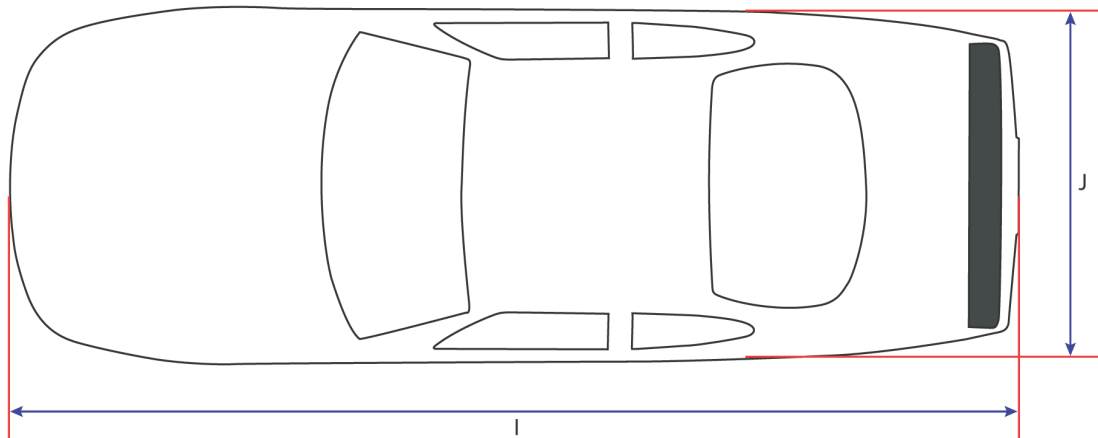

- Truck Bodies:**
- A: 3.25"
 - B: 4.00"
 - C: 7 degrees
 - D: 35 degrees
 - E: 60 degrees
 - F: 3.75"
 - G: 7.50"
 - H: 12.75"
 - I: 44.00-49.00"
 - J: 17.50-19.50"

QUARTER SCALE CAR MANUFACTURERS

Bob's Motorsports
 Henderson, NV
 Phone: (702) 210-3961
 Website <http://www.bullseye.9f.com>

CAT 5 Manufacturing
 Monon, Indiana
 Phone: (832) 928-3543
 Website <http://www.quarterscalecar.com>

JR QuarterScale
 Ravenna, Ohio
 Phone: (330) 296-4354
 Website <http://freddieshobbies.com>

PRO1 RACING
 Konawa, Oklahoma
 (405) 584-2510
 Website <http://www.pro1z.com>

QUARTERSCALE MOTORSPORTS
 Rancho Cucamonga, California
 Phone: (800) 266-7745
 Website www.quarterscalemtrsports.com

WCM CORPORATION
 Madisonville, Texas
 Phone: (936) 348-5057
 Website <http://www.wcm-corp.com>



TECHNICAL SPECIFICATIONS

GRAND NATIONAL STOCK CARS

- Minimum Height 10.50 inches
- Overall length 44.00 - 49.00 inches
- Wheelbase 25.00 - 27.00 inches
- Overall width* 17.50 - 19.50 inches
- Track Width** 16.50 - 19.25 inches
- Weight 30 pounds - minimum

* Overall width is measured at the car's widest point

** Track width is defined as "outside of tires". Track width differential front to rear may not exceed 1.50 inches at any time.

Unless otherwise listed below, all other specifications from the General Specifications apply. Grand National competitors may not compete in the Sportsman Class during the same event.

BODIES (11.12.05)

1. Cars must appear as NASCAR Grand National or Nextel Cup cars, must be attractively painted and have and maintain a scale appearance.
2. Cars must have windshields front and rear either as cutouts replaced with another solid plastic material or as outlines painted as windows with a contrasting color.
3. No lightening or ventilating of the body except as in the car's full size counterpart (grill opening, windshield cowl, etc.). No holes allowed in the rear of the body.
4. Wheel openings must be full cutouts.
5. No underbody ground effects.
6. Roof rails, allowed as molded-in by body manufacturers, may not exceed .25 inches in height.
7. Belly-pans limited to 208 square inches. No full width belly-pan extensions past the front or rear axle line. (11.22.07)
8. Add on rear spoilers may not extend more than 3" in any direction from the factory deck as measured at the back edge of the rear deck. Spoiler may be of any material, but all edges must be rounded and smooth. The spoiler must be mounted on the rear of the body (just like the full scale version) not on top of the rear deck.
9. No bends or lips on the top or ends of the spoiler allowed. (Also applicable to Sportsman, Novice Stock-car, and Super-Truck).
10. Body's rear bumper flange may not be trimmed to less than 1" from the molded bumper as measured from the inside of the flange.
11. The top surface of the front and rear bumpers must be at or above the wheel centerline.
12. Foam bumpers (front and rear) are mandatory and must maintain a minimum of .25 inch ground clearance during full compression of the suspension. The top surface of the front and rear bumpers must be at or above the wheel centerline. The outside perimeter of both bumpers must be within .50" of body. (11.22.07)
13. Engine exhaust may be routed through a single 1.25 square inch cutout, located in the side of the body between the front and rear tires and below the centerline of the front and rear axles. The cutout must not interfere with the cars side number (s). No exhaust ductwork shall extend beyond the body. (11.12.06)

CHASSIS (11.12.05)

1. Cars must have independent A-Arm type front suspension.
2. A-Arm mounting points must be equal-distance from the chassis centerline.
3. Lower control arms must be of equal length (plus or minus .125 inch) as measured from the centerline of the inner mounting point to the centerline of the ball-joint. There is a tolerance of .125 inch for each lower control arm, that is to mean that the overall differ-

ence between the left and right lower control arms is .250 inch.

ENGINE

1. Engine Zenoah G2D-70 (both two-ring and single-ring versions), and the Zenoah G23RC/G230RC (versions A & B) are allowed.
2. Engines must be as manufactured, no mixing of components between versions or up-rated -44, 57 -cylinder 1148-12111 (to the 2HP version) may be used. Example: You cannot use a two-ring piston with a single-ring cylinder or a single-ring piston with a double-ring cylinder. The G-23RC / G230RC (versions A & B) have interchangeable parts. Each version will have its own set of specifications and will be checked accordingly. Example: Version A engine with a version B cylinder will be teched as a version B engine. If your engine has version B parts it will be teched as a version B engine. If you have any questions please contact the National Tech Director Randy Brown @ (517) 641-4452.

CARBURETOR (11.22.07)

The Walbro WY-1 Series, (-1, -16, etc) or the Walbro WYK Series (32, 51,194) carburetors are allowed with a 10.5 restrictor / adaptor plate, two gaskets mandatory and no sealant. See page 20 (look under Carburetors for ordering information) The plates are mandatory.

TIRES

Tires must fit within the car's body.

FUEL

Gasoline only

TECHNICAL SPECIFICATIONS

SPORTSMAN STOCK CARS

- Minimum Height 10.50 inches
- Overall length 44.00 - 49.00 inches
- Wheelbase 25.00 - 27.00 inches
- Overall width* 17.50 - 19.50 inches
- Track Width** 16.50 - 19.25 inches
- Weight 30 pounds - minimum

* Overall width is measured at the car's widest point

** Track width is defined as "outside of tires". Track width differential front to rear may not exceed 1.50 inches at any time.

Unless otherwise listed below, all other specifications from the Grand National and General Specifications apply.

Sportsman competitors may run in the Sprint Car and Super Truck classes during the same event. They can not compete in the Grand National class at that event.

ENGINE, FILTER, VELOCITY STACK (11.12.05)

G2D-44 / 57 cylinder on G2D-70 cases, or G2D-44/57 base, G2D-70, G-23RC/G230RC (A & B) engines with the QSAC approved air filter adapter (replaces the velocity stack) allowed -**or-** the stock OEM Zenoah air filter and housing.

CARBURETOR and CARBURETOR / PLATE OPTIONS (11.22.07)

The Walbro WYL 99, 78, 79, and 115 carburetors are allowed with two gaskets mandatory, no sealant and 8.5 mm QSAC restrictor plate.

The Walbro WY-1 Series, (-1, -16, etc) or the Walbro WYK Series (32, 51,61,194) carburetors are allowed with a 8.5 restrictor / adaptor plate, two gaskets mandatory and no sealant. See page 20 (look under Carburetors for ordering information) The plates are mandatory.

Note #1: The QSAC approved air filter adapter is available from Bishop Racing Products. Please contact Todd Bishop at (479) 751-6232 or by e-mail: tbishop44@cox-internet.com to purchase.

TECHNICAL SPECIFICATIONS

Novice Class

- Minimum Height 10.50 inches
- Overall length 44.00 - 49.00 inches
- Wheelbase 25.00 - 27.00 inches
- Overall width* 17.50 - 19.50 inches
- Track Width** 16.50 - 19.25 inches
- Weight 30 pounds - minimum

* Overall width is measured at the car's widest point

** Track width is defined as "outside of tires". Track width differential front to rear may not exceed 1.50 inches at any time.

Unless otherwise listed below, all other specifications from the Grand National, Sportsman, and General Specifications apply.

- Novice class is an entry-level class for drivers new to Quarter-Scale racing.

- Competitors in the Novice class may not participate in any other class while remaining a novice. Further, once leaving the novice class to progress to a "Pro (cash payout) class", he / she may not return to Novice unless approved by the QSAC Area, Region, or District Director, and his "home track" or club.

- Competitors in the Novice class will receive trophies or plaques only, no cash awards or points.

TECHNICAL SPECIFICATIONS

SUPER-TRUCK

- Minimum Height 11.75 inches
- Overall length 44.00 - 49.00 inches
- Wheelbase 25.00 - 27.00 inches
- Overall width* 21.50 inch Maximum
- Weight 30 pounds - minimum

* Overall width is measured at the car's widest point

Unless otherwise listed below, all other specifications from the Grand National and General Specifications apply.

1. Trucks must appear as current NASCAR Super-Trucks, must be attractively painted and have and maintain a scale appearance.
2. Trucks may use the Raco Stadium Truck Body, the PRC NASCAR Super-Truck Body, or subsequent Super-Truck body approved for use by QSAC.
3. Must have windshields front and rear either as cutouts replaced with another solid plastic material or as outlines painted as windows with a contrasting color.
4. Maximum spoiler is 3.00 inch measured in any direction from top of rear deck, any material, but corners must be rounded and smooth with no sharp edges. No bends or lips at top or sides of spoiler allowed.
5. On certain chassis, roll bar and/or spark plug interference prevents seating the Super-Truck body properly on the front and rear bumpers. To alleviate this interference, it is permissible to cut out the body, using Slot-type relief's for roll bars and a rear-window/deck cut-out for the sparkplug. In both cases, such cuts must be kept to an absolute minimum. If, during pre-race tech, cutouts are deemed to be excessive, the competitor may be required to temporarily fill part of the cutout using duct-tape or other material.
6. Engine must conform to the Stock Car and General specifications.



TECHNICAL SPECIFICATIONS

SPRINT CAR SUPER-MODIFIED

- Overall length 32.00 - 40.00 inches
- Wheelbase 20.00 - 23.00 inches
- Overall width* 20.00 inches Maximum (5/4/2009)
- Weight** 22 pounds - minimum

* Overall width is measured at the outside of tires

** Before and after race

Unless otherwise listed below, all other specifications from the Grand National and General Specifications apply.

SPRINT CAR

1. Sprint Cars must resemble "World Of Outlaw" or USAC cars.
2. Mean center of frame to outside of any tire not to exceed 10.00 inches.
3. Wheels must be scale appearing 3.75 inch diameter (at tire bead), plus/minus .25 inch.
4. Right rear minimum tire circumference (rollout) of 17.00 inches before and after race.
5. Exhaust systems outside the perimeter of the basic chassis must be located below the level of the top main chassis rail (not roll cage) and within the perimeter of the left or right side nerf bar.
6. The exhaust system may not extend beyond the rear axle. If the pipe IS within the perimeter of the chassis, then it may extend beyond the rear axle, but must be within the confines of the rear body/tank shell.
7. All cars shall be straight axle, front and rear. This is to mean no independent suspensions.
8. Cars must have scale appearing right and left side nerf bars and shall not extend more than .75 inches outside the tires. If a front bumper is used, it must be scale appearing, it must be no wider than the main frame rails, and it shall not extend more than 2 inches from the front of the main frame. If a rear bumper is used, it must be scale appearing.
9. Top wing shall not exceed 14 inches wide and 16 inches long. Overall sideboard: height 7 inches, length 18 inches. **(12.15.08)**
10. Top wing must be mounted so that the bottom surface of the top wing (point closest to the top of the cage) is a minimum of 1.50" above the roll cage. **(12.15.08)**
11. Front wing shall not exceed 8 inches wide and 6 inches long. Overall sideboard: height 3 inches, length 8 inches.
12. Car numbers must appear on both sides of the top wing and tail tank, minimum 3 inches high, and must be clearly visible from scoring stand during race.
13. Engine must conform to the stock car and general specifications.
14. Zenoah G2D-70 (2HP) G-23RC / G230RC (versions A & B) must use the stock Zenoah OEM Muffler and use gasoline only.
15. Use the same carburetor and mandatory restrictor / adaptor plates as the Grand National technical specifications. **(11.22.07)**
16. Wheel widths as follows: LF & RF: 2" min. / 2 3/4" max. ; LR: 2 1/2" min. / 3" max. ; RR: 3" min. / 4" max. (Example a 3" wheel can have a 3.25" tread and a 3.75" host.) **(11.22.07)**

SUPER MODIFIED

1. Cars must resemble eastern or western style full size open wheel super modified bodies.
2. Front hoods are mandatory, tail sections optional.
3. No full bodies
4. Front and rear bumpers required but may not exceed the car's track width.
5. Mean center of frame to outside of the rear tire not to exceed 10.25 inches.
6. Top wing maximum size (including sideboards) 16 inches long, 12.50 inches wide maximum.

7. Sideboard height is 7.00 inches overall and 18.00 inches long.
8. Front wing maximum size is 6.00 inches long, 8.00 inches wide.
9. Body parts may be airfoil in design.
10. Any wing material may be used.
11. Sideboards must be flexible with no sharp edges.
12. Exhaust systems may be mounted outside the car's frame but within the length, width and height of the car.
13. Right and left side nerf bars or equivalent are required but may not extend beyond the outside edge of the tires.
14. Minimum right rear tire circumference of 17.00 inches before and after race.
15. Engine must conform to the stock car and general specifications.
16. Zenoah G2D-70 (2HP) , G-23RC / G230RC (version A & B) must use the stock Zenoah OEM Muffler.
17. Use the same carburetor and mandatory restrictor / adaptor plates as the Grand National technical specifications. **(11.22.07)**

EAST-COAST MODIFIED

1. The Rules for this class duplicate the chassis requirements of the Grand National, and will utilize a Body resembling the "DIRT" Modified-Cars as run on the East coast, or the IMCA Modified cars used elsewhere in the country.
2. A molded body for the class may be available in the near future; in the meantime, hand-fabricated bodies will continue to be acceptable.

DRAG RACING

1. Track Sanctioning shall be per QSAC requirements.
2. Contact Ken Jones @ (909) 350-9952 or Mike Moore at (513) 742-0280 for info on specific classes and class rules.

ENGINE TECHNICAL INSPECTION

The QSAC engine rules are written to mean absolutely no engine modification is permitted and includes specifically that the addition or removal of material is not allowed. The rule as written and currently enforced is one of the foundation blocks of QSAC and Quarter Scale Racing. The publication of this procedure is meant as a method for contestants to check their own engines for compliance to the rules. It is not meant as a guide for "blueprinting" an engine within the parameters. An engine found to be altered, even though it may measure legal, will be disqualified and the altered parts will be confiscated and destroyed.

To perform the procedure, a 2.00 inch stroke dial indicator and a spark plug hole adaptor will be needed. The carburetors, carburetor mounting block, exhaust system, and flywheel cover must be removed. All the measurements are based on the downward stroke of the piston from the top dead center as the flywheel is rotated counter-clockwise when viewed from the flywheel end of the engine. There are five measurements that, performed as instructed below, will determine:

1. Intake Port Timing - Full Open
2. Intake Port Timing - Start Open
3. Intake Port Timing - Maximum Port Window Size (height)
4. Exhaust Port Timing - Start Open
5. Crankshaft Stroke

PROCEDURE:

INTAKE PORT - FULL OPEN

After finding top dead center and setting the dial indicator at zero, rotate the flywheel counter-clockwise until the piston skirt just enters the intake port at the top. Note the measurement and refer to the chart.

IGNITION TIMING-- (G2D-44 & 70) Rotate the flywheel counter-clockwise, align forward leg of the coil with the forward edge of the 2nd or center flywheel magnet-- check alignment carefully-- read dial/ refer to the chart. (G23-RC/G230RC) – Rotate the flywheel counter-clockwise, the leading edge of the first magnet lines up with the back edge of the coil -- check alignment carefully-- read dial/refer to the chart.

INTAKE PORT - START OPEN

Rotate the flywheel counter clockwise till the piston skirt fully closes the intake port at the bottom. Refer to the chart.

INTAKE PORT - MAXIMUM PORT HEIGHT

The maximum intake port height (roof to floor) may not exceed .345, as measured by subtracting the intake port - full open figure (.015 or more) from the intake port - start open figure (.372 or less)

EXHAUST PORT - START OPEN

Rotate the flywheel counter clockwise till the piston crown begins to open the exhaust port at the top. Refer to the chart.

CRANKSHAFT STROKE

Rotate the flywheel counter clockwise to bottom dead center. Refer to chart.

Specifications	G2D-44	G2D70 (2-ring)	G2D70 (1-ring)	G-23RC/G230RC "A"	G-23RC/G230RC "B"
Intake-port, Full-open (IPFO)	.015 or more	.008 or more	.060 or more	.065 or more	.080 or more
Intake-port, Start-open (IPSO)	.372 or less	.415 or less	.465 or less	.480 or less	.520 or less (9.10.07)
Maximum port-Window size	.345 or less	.395 or less	.395 or less	.408 or less	.425 or less
Exhaust-port Start-open (EPSO)	.770 or more	.740 or more	.670 or more	.655 or more	.665 or more
Maximum Stroke	1.105 or less	1.105 or less	1.105 or less	1.105 or less	1.105 or less
*Maximum Timing	Open	Open	Open	Open	Open

Please Note: We are currently working on a procedure to check the bore size of the cylinder heads for the G230RC "A" and "B" engines. The new procedure will be implemented for the QSAC Showdown N.C.S. races.

The stock fly wheel key WITHOUT MODIFICATION must be installed in all engines.

Legal Phenolic Blocks: Zenoah OEM part #1148-13161, existing blocks and Zenoah part # 1870-13160 (11.22.07)

TECHNICAL SPECIFICATIONS: SPRINT CAR

CHASSIS

Car must resemble a "World of Outlaws" or "USAC" Sprint Car and meet all dimensional specifications as shown below:

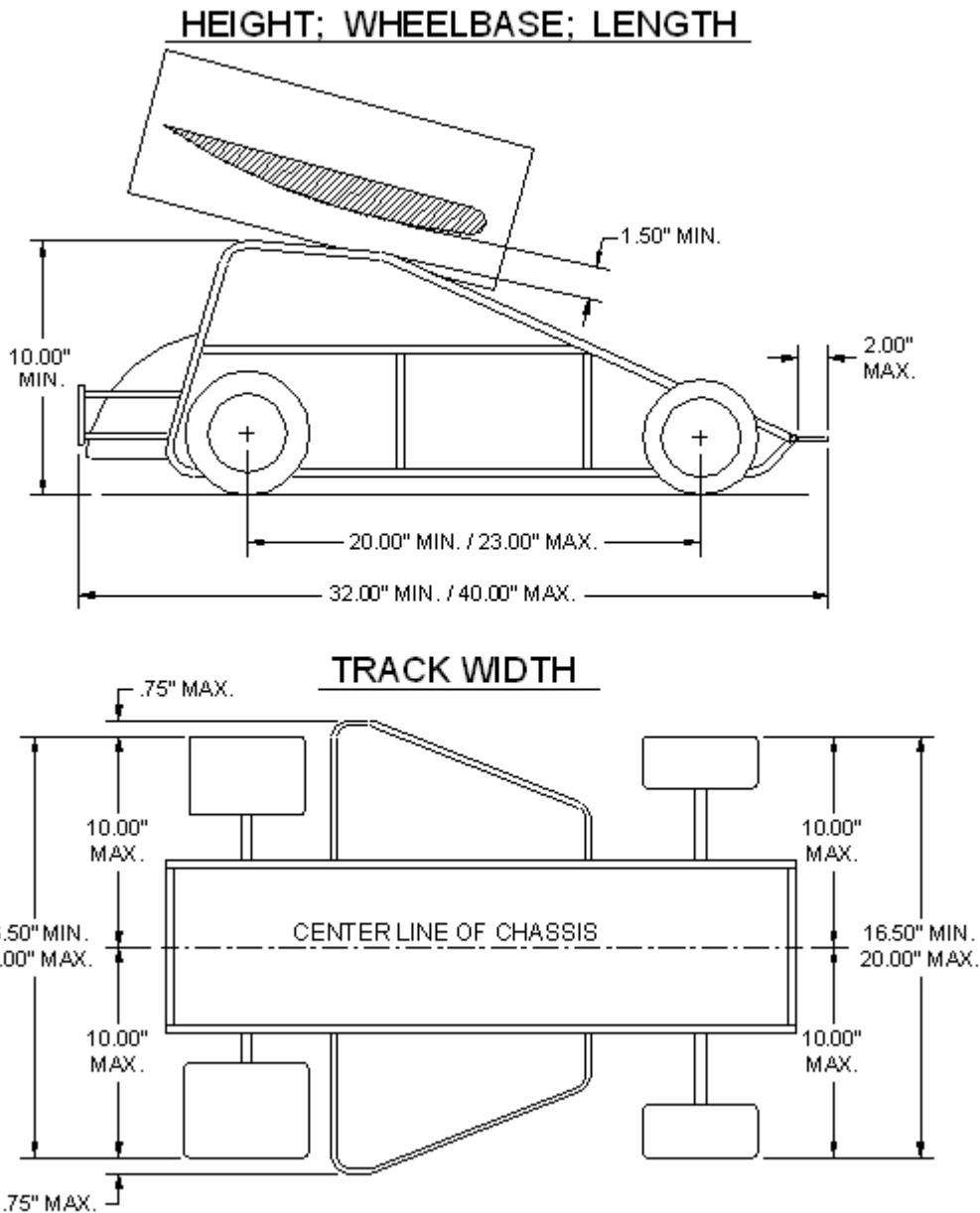

WEIGHT:

22 pounds minimum (empty fuel tank).

SUSPENSION & DRIVETRAIN

All cars must be straight axle, front and rear. This is to mean no independent suspension.

Suspension may be Coil Over and/or Torsion Bar.

Maximum of (4) shock absorbers.

Rear End Differentials (ball diffs, floater hubs) are allowed but not required.

Quick Change Gear Rear Ends (Skellenger, New Era, etc.) are allowed but not required.

BODY & WINGS

A scale appearing hood, tail tank, and top wing are required. Front wing is optional.

Top wing must be mounted so that the bottom surface of the top wing (point closest to the top of the cage) is a minimum of 1.50" above the roll cage.

No side foils, rudders, or panels are to extend beyond rear cage support bars.

Wings may be constructed of any material but must be flexible with no sharp edges.

Wings must meet all dimensional specifications as shown below: Except when racing on dirt. (Dirt wings **may be** 15 X 15)

TOP WING

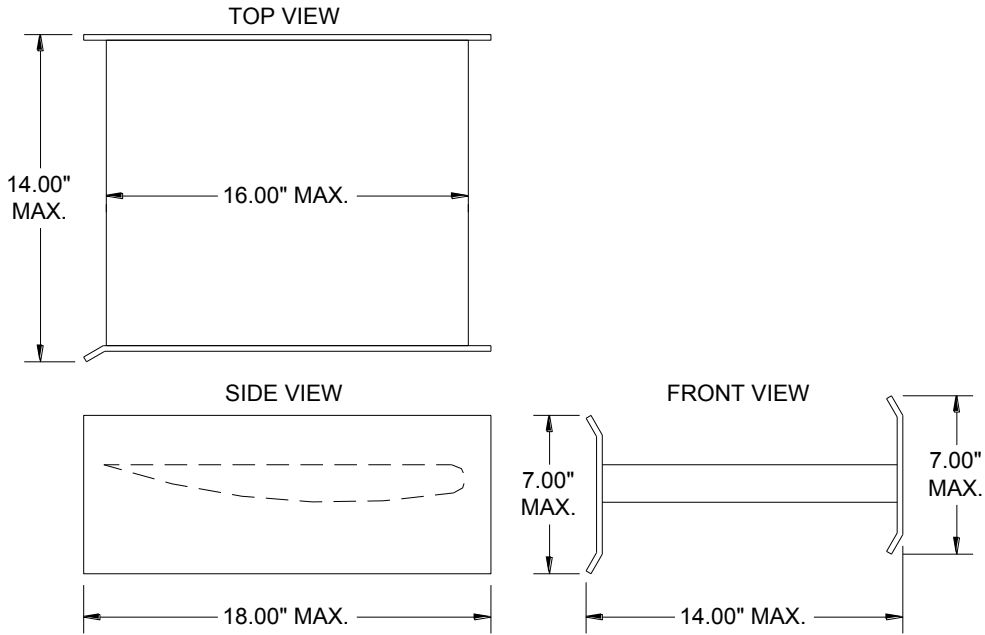

FRONT WING

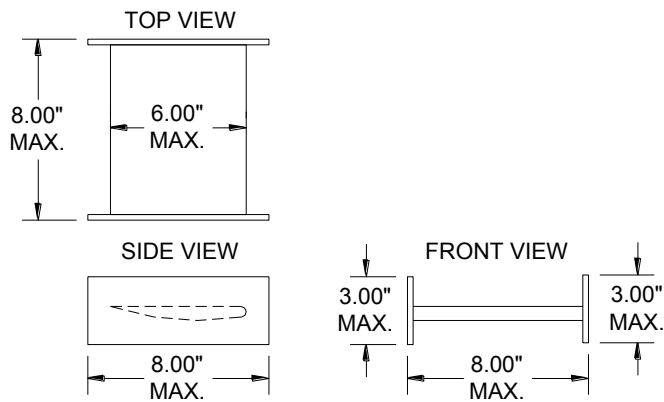

BUMPERS AND NERF BARS

Nerf Bars are required on both the left and right side of the car and must be scale appearing. Nerf Bars may extend up to .75" past the outside edge of tires.

Front Bumper is recommended but not required. If used; must be scale appearing, not to exceed the width of the main frame rails, and not to extend more than 2" from the front of the main frame.

Rear Bumper is required and must be scale appearing.

If during a race the bumpers or nerf bars are damaged in an accident to the point of being a hazard to other competitors, the parts can be removed to finish the race but must be on the car as required to start the race.

CAR NUMBERS

Car numbers must appear on outside of the top wing sideboards and both sides of the tail tank. Numbers must be a minimum of 3" high and clearly visible from the scoring stand during races.

SCORING TRANSPONDERS

Scoring transponders (personal or track transponder) must be mounted behind the center line of the front axle.

ENGINE

Must conform to all ENGINE requirements under the QSAC GENERAL SPECIFICATIONS.

Allowed Engines:

Zenoah G23RC/G230RC (versions A & B)

Zenoah G2D-70 (both two-ring and single-ring versions)

EXHAUST

Must conform to all EXHAUST requirements under the QSAC GENERAL SPECIFICATIONS.

Stock Zenoah Mufflers only. Tuned expansion chamber exhaust systems, "pipes", etc. are NOT allowed.

Exhaust may be redirected by use of a piece of 1.00 inch (ID) or larger hose or tube. Hose or tube that extends past the outside perimeter of the basic chassis must be located below the top main chassis rail (not the roll cage), within the perimeter of the right and left side nerf bar, and must not extend past the rear axle. Body panels that extend down the bottom frame rail can be trimmed to accommodate exhaust systems clearance.

CARBURETOR

Must conform to all CARBURETOR requirements under the QSAC GENERAL SPECIFICATIONS.

The Walbro WY-1 Series, (-1, -16, etc) or the Walbro WYK Series (32, 51,194) carburetors are allowed with a 10.5 restrictor / adaptor plate, two gaskets mandatory and no sealant. See page 20 (look under Carburetors for ordering information) The plates are mandatory.

CLUTCH

Must conform to all CLUTCH requirements under the QSAC GENERAL SPECIFICATIONS.

FUEL

Gasoline only per QSAC GENERAL SPECIFICATIONS.

FUEL SYSTEM

Maximum 8 oz. capacity fuel tank and will be mounted within the perimeter of the main frame rails.

All fuel lines and filler lines must be .125" inch maximum ID.

Maximum fuel line length of 30 inches which includes a maximum of two .125 inch ID x .50 inch OD x 1.25" long fuel filters, fill, feed, return and vent lines. Tubing located inside the fuel tank is excluded from this measurement.

WHEELS / RIMS

All wheels / rims must be scale appearing.

Wheel Diameter (measured at the bead):

All wheels must be 3.50" minimum / 4.00" maximum diameter

Wheel Width (measured at the bead):

Left Front: 2.00" minimum / 2.75" maximum width

Right Front: 2.00" minimum / 2.75" maximum width

Left Rear: 2.50" minimum / 3.00" maximum width

Right Rear: 3.00" minimum / 4.00" maximum width

Minimum 2 lugs per wheel.

Knockoff style wheels and hubs are allowed but not required.

TIRES

Sprint Cars must use the QSAC approved right front tire-bands. Approved compounds for all tires are the same as the Stockcar and Super Truck classes as described in the TIRES AND WHEELS requirements under the QSAC GENERAL SPECIFICATIONS.

Spike tires are allowed for dirt use only.

Sidewall / Host Width:

Left Front Host: 2.00" minimum / 2.875" maximum width

Right Front Host: 2.00" minimum / 2.875" maximum width

Left Rear Host: 2.50" minimum / 3.75" maximum width

Right Rear Host: 3.00" minimum / 4.50" maximum width

Tread / Band Width:

Left Front: 2.00" minimum / 2.75" maximum width

Right Front: 2.00" minimum / 2.75" maximum width

Left Rear: 2.50" minimum / 3.25" maximum width

Right Rear: 3.00" minimum / 4.00" maximum width

Tire Circumference:

The Right Rear tire must have a minimum circumference (rollout) of 17" before and after race.

Unless otherwise listed, all requirements from the QSAC GENERAL SPECIFICATIONS apply.

QSAC SANCTIONED TRACKS IN 2010

BOULDER CITY R/C SPEEDWAY

1101 Quail Dr.
Boulder City, Nevada 89005
Website <http://www.qsara.org>
Lance Cote (702) 491-3213

CAROLINA RC SPEEDWAY

4148 Calhoun Memorial Hwy
Easley, SC. 29640
Website <http://www.carolinarc.com>
Craig Prahll (864) 895-4492

COODY CREEK SPEEDWAY

620 9th St. SE
Muskogee, OK. 74401
Website <http://www.coodycreekspeedway.com>
(918) 682-9398

DALLAS/FORT WORTH QUARTER SCALE AUTO CLUB

12480 Rendon Road
Burleson, Texas 76028
Website <http://www.dfwrc.com/>
Mike Sadler (214) 542-2325

FREDDIE'S ASPHALT OVAL

100 Romito St. Ravenna
Ohio 44266
Website: <http://www.freddiesasphaltoval.com/index.html>
Fred Miavitz (330) 296-4354

FUNTYME PARK R/C RACEWAY

6245 E. Saginaw Blvd,
North Lansing, Michigan 48837
Website <http://www.glqsr.com>
Randy Brown (517) 641-4452

HIDEAWAY SPEEDWAY

25363 University Ave NE
Isanti, MN. 55040
LeRoy & Sandy Nelson (763) 444-4804

INGALLS MOTOR SPEEDWAY

300 Menden Road
Ingalls, Indiana 46048
Website <http://www.indyquarterscaleracers.org>
Rick Gauger (317) 898-8112

Lake Side Speedway

959 Wilmouth Road
Clover, SC 29710
Steve Bess (704) 363-6494

LAGOON PARK R/C RACEWAY

2730 Lagoon Park Drive
Montgomery, AL 36109
Website <http://lagoonparkraceway.com>
Allen Johnson (334) 657-7797

MACHESNEY PARK RACEWAY

1220 Shappert Dr.
Machesney Park, Illinois 61115
David Pirrelo (815) 742-8373

MILESTONE PARK

12685 Holly Street
Riverside, California 92509
Larry Cross (909) 887-9700

NORTHWEST R/C SPEEDWAY

2881 E. Sagemoor Road
Pasco, WA 99301
Website <http://groups.msn.com/WSQSAC>
Clay Nulle (509) 845-1574

NITRO PIT, LLC

19000 W Happy Valley Road
Wittman, AZ 85361
Tony Evans (623) 203-0886

OrangeShow QMRA

689 South "E" Street
San Bernadino, CA 92408
DENNY (909) 638-8976

VETERANS PARK SPEEDWAY

Veterans Park
Hwy. 169 & North Park Drive
Algona, Iowa 50511
Website <http://www.veteransparkspeedway.com>
Rick Klein (515) 295-2159





QUARTER SCALE AUTO CLUB, INC

CORPORATE BYLAWS

EFFECTIVE: JANUARY 1ST, 1995

Revised: October 11th, 2004

QUARTER SCALE AUTO CLUB

CORPORATE BY-LAWS

Table of Contents

- I. Preface
- II. Quarter Scale Auto Club By-Laws
- III. QSAC Management Team
 - A. Board of Directors
 - 1. Elections
 - a. Board Co-Chairmen
 - b. Nominations/Ballots
 - c. First Election
 - 2. Non-Fulfillment of Term
 - 3. Impeachment/Dismissal/Appointment
 - a. QSAC CO-Chairmen – Impeachment
 - b. Appoint/Dismissal
- IV. QSAC Committee Charters
 - A. Finance
 - B. Rules
 - C. Competition
 - D. Long Range Planning
 - E. Manufacturer's Advisory
 - F. Special Projects
 - G. Sub-Committees
 - 1. Product Review
- V. Field Organization Charters
 - A. District Director
 - B. Region Director
 - C. Area Director
- VI. Supplements
 - A. Organization Chart



I. Preface

The Quarter Scale Auto Club (QSAC) is a non-profit corporation chartered in the State of Michigan. QSAC's purpose is to provide a sanctioning body to organize and direct the sport of quarter scale radio controlled racing in the United States.

The primary functions of the organization are to provide establishment and uniform enforcement of safety and competition rules, liability insurance for the membership, and the promotion and growth of the sport through a strong, fair and unbiased management organization.

II. Quarter Scale Auto Club By-Laws

The intent and purpose set forth by the by-laws here-in is to establish the formal organization and charter for the Quarter Scale Auto Club, Inc. (QSAC, Inc.) and chartering a strong management team to organize, promote, and stimulate the growth of quarter scale radio-controlled auto racing. The management team shall be entirely voluntary, and shall embrace the "Spirit and Intent" of promoting the sport, and conducting the business of QSAC on behalf of, and for the benefit of, the QSAC general membership. "Spirit and Intent" is defined as the honest governing of the body, free of outside interest or influence either personal or financial, insuring to the general membership the management's' commitment to the betterment of the sport with the general memberships' best interest and concerns at heart. The structure of this organization is detailed in the following pages.

III. QSAC Management Team

A. Board of Directors

The QSAC Board shall be comprised of two Co-Chairmen, having equal authority and responsibility with regard to the operation of the Sanctioning Body. Each Co-Chair's term shall be two years, with alternate year term expiration. That is, one Co-Chair's term shall expire each year, yielding alternate year term expiration for each Co-Chair. This alternating term expiration will provide continuity of management, meaning that the remaining Co-Chair shall assist the transition of the newly elected Co-Chair to the duties and responsibilities of his office while maintaining an experienced management presence during that transition.

The Co-Chairs will be responsible for selection and appointment of all other management team positions (committee chairmen) as well as administrative positions (secretary and treasurer). The Co-Chairs shall maintain the organizational chain of command and consider the written input of the committees in the decision-making processes of managing the business of the organization. The Board Co-Chairs shall have the ultimate responsibility of, and authority to conduct the business of QSAC, and the Board's decisions shall be final and binding. Requests for funds whether for expense reimbursement or capital expenditure can only be authorized by consensus approval of the Co-Chairs.

1. Elections

- a. The Board Co-Chairmen shall be the only elected officials in the QSAC organization. Election will be held annually, electing one Co-Chair per year, with each fulfilling a two-year term starting November 1st. A Co-Chairman may be elected to as many terms as he is willing to faithfully serve. The "Spirit and Intent" of Board nominations shall be free of conflicting interest, and as such, those persons on record as being industry related suppliers or manufacturers or are considered such by a consensus of the management team shall be ineligible for nominations/election. While there is no implication intended that manufacturers could not "serve faithfully", it is important to limit "undue influence" and level the playing field for all.
- b. It is intended that experience within the organization be a prerequisite for nomination for a Board Co-Chairmanship. As such, eligibility for nomination to the position are limited to currently serving Committee Chairmen, District Directors, Region Directors, and Area Directors. A nominating committee consisting of the two existing Board Co-Chairmen and three members-at-large shall interview all potential candidates from the pool of eligible persons defined in the foregoing, determining each person's ability and willingness to serve. The nominating committee shall then present to the general membership a minimum of one and a maximum of three qualified candidates for consideration. The candidate name or names together with a brief bio will be published each year in the June issue of the newsletter, together with a ballot. The ballot **MUST** be returned to the QSAC Secretary at the QSAC Information Center not later than September 1st in order to be counted.
- c. The first QSAC Board Co-Chairman election will take place in 1995. Rotating to the remaining current Co-Chairman in 1996, etc.. The decision as to which existing Co-Chairman will commence the process will be between the existing founding Co-Chairmen.

2. Non-Fulfillment of Term

If, for any reason, a Co-Chairman cannot complete his/her term, the remaining Co-Chairman

may select a replacement to fulfill the remainder of that term with the consensus approval of the six major Committee Chairmen. Non-Fulfillment shall also include resignation and impeachment.

3. Impeachment/Dismissal/Appointment

a. QSAC Co-Chairmen – Impeachment

The mechanism for removal of a Co-Chairman shall be the consensus opinion of the six major Committee Chairmen (Rules, Competition, Long-Range, Special Projects, Finance, and Manufacturer’s Advisory) and the remaining Co-Chairman. A Co-Chairman or Committee Chairman must present the petition for a vote of confidence. A resulting “no-confidence” vote would result in the immediate removal of the affected Co-Chairman.

b. Appointment/Dismissal

The QSAC Co-Chairmen shall have sole authority to appoint or dismiss any organizational or administrative position in the corporation, including Committee Chairman, District Director, Treasurer, or Secretary.

IV. QSAC Committee Charters

The following is a review of the charters of each of the formal Committees within the organization. It is the responsibility of each Committee Chairman to assure the proper execution of the duties of the Committee as defined by the charter of the Committee, and to review the results of the committee’s activities with Co-Chairmen on a regular basis.

A. Finance Committee

The committee will review the income and expenses of the prior year and, based on revenue projections, make recommendations on budgets for the coming year. The committee will also advise on methods to generate new income sources for the organization, and using recommendations of the Competition and Long-Range Planning Committees, review the organization’s capabilities to finance new programs for the benefit of the membership. The committee shall also be responsible to review *proposed* uncheduled or unbudgeted expenditures to determine if resources are available to fund such expenditures. Additionally, the committee will be responsible for the filing of corporate tax returns as required, and the review and approval of the annual financial statement prior to its presentation to the membership via the QSAC Newsletter.

B. Rules Committee

The primary function of the committee is to gather input from the Competition, LRP, and Manufacturers’ Advisory Committees, as well as District, Region, and Area Director’s field, and review and recommend change to the prior year’s Rules Package to “fine tune” the Package for the coming racing season/year. Since it is the goal of the organization to maintain a stable Rules-set, absent of massive, disruptive changes from year to year, care must be exercised to consider each proposed change with an eye toward its impact on the membership, as well as each of the industry manufacturers.

C. Competition Committee

The committee shall be responsible to gather input from the other committees, the field organization and the membership at large to determine what changes in safety and race format would be beneficial to the membership and the sport of Quarter Scale RC racing in general. The committee shall also be responsible to serve as a “clearing house” for race dates on the National, District, and Regional schedules, review and resolve possible conflicts and recommend possible additional events. Further, the committee shall review all sanction requests to insure all sanction requirements are met prior to the issuance of a sanction. Key to the function of this committee will be the close, continuous contact with the QSAC Field Organization that is the primary collection point of information and ideas from the general membership.

D. Long-Range Planning Committee

The committee shall gather input from all committees and the field organization, and, working closely with the Finance Committee, construct a “rolling” five-year plan. As part of their long-range planning, the committee should formulate plans and methodologies to promote QUARTERSCALE and QSAC on a National, and possibly international basis, develop potential Corporate Sponsorship opportunities, and explore potential mutually beneficial affiliations with other organizations. The committee is the concept group of QSAC, with the responsibility to review and evaluate the ideas and suggestion of QSAC as a whole. All ideas, no matter how seemingly outrageous or impossible, shall be thoroughly reviewed and evaluated. The committee shall work extremely closely with the Special Projects Committee to find ways to promote QUARTERSCALE and QSAC.

E. Manufacturer’s Advisory Committee

The committee is comprised of all QUARTERSCALE Industry Manufacturers of record on Jan 1 of each year, shall elect its chairman every 3rd year, who



will then be responsible to input group consensus recommendation to the appropriate committees for review. The committee shall input to all major committees and shall present thoughtful, well-considered recommendations with the interests of the competitors and manufacturers in mind.

F. Special Projects Committee

The committee shall be responsible for public and media relations and shall be the primary developer of Corporate Sponsorships. Compilation and publishing of promotional materials, together with principal contact responsibility with print, radio, and television media shall be the primary function of the committee, in pursuit of continuous effective promotion of QUARTERSCALE and QSAC. This committee shall, as with the other committees, report directly to the Co-Chairmen, who have discretionary authority to fund minimal expenditures this committee may propose. The committee shall "keep its finger on the pulse" of QSAC through regular contact with the other committees and the field organization.

G. Sub-Committees

From time to time, the Co-Chairmen may appoint sub-committees or ad-hoc committees to study a particular problem or situation, and make recommendations to the Co-Chairmen or the major committees.

1. Product Review Sub-Committee

Originally empanelled as an ad-hoc committee in February '93, this committee, comprised of the Chairmen of Rules, Long-Range Planning and Competition Committees, chaired by the Competition Committee Chairman, is now a permanent sub-committee of the Competition Committee. The sub-committee is chartered to review and evaluate new products and determine their "impact" on the sport, as well as the applicability and acceptability of the product in relation to the QSAC Rules, including "spirit and intent".

V. Field Organization – Charters

The Field Organization is comprised of Area Directors, reporting to Region Directors, reporting to District Directors. It is intended as a field management "team", designed to be the principal point of contact between the National Organization and the general membership. The field organization is the "face" of the National Organization, representing QSAC to the membership and the general public, in most cases presenting the "image" of QSAC, and as such, plays an extremely important role in QSAC.

There are three Districts across the country, each District having from one to three Regions, and each Region having as many Areas as necessary to adequately serve the membership.

A. District Director

The District Director is responsible for the coordination of all activities within his/her District. The Director is responsible to assemble his "team" of Region and Area Directors, and has the ultimate authority to appoint or replace subordinate positions as necessary to accomplish the tasks of the District. The District Director position is a direct appointment of the Co-Chairmen of QSAC.

Included within the purview of the District Director are responsibilities for Major event scheduling within the District, and in concert with his peers and the Competition Committee Chairman, resolving event-scheduling conflicts on the national level. Further, he is responsible for providing an open door for the comments and ideas from the general membership, and resolving disputes within the District. The District Director is also responsible to forward, in writing to the appropriate committee or the Co-Chairmen, any problem or dispute irresolvable at the District level or below.

B. Region Director

Appointed by and reporting to the District Director, the Region Director is responsible for the implementation of plans and programs of the National organization and the District Director within his/her Region. The Region Director is also responsible to identify and appoint able and effective Area Directors to provide direct contact for the membership in areas outside his immediate area. The Region Director has the authority to appoint or replace Area Directors as is required by the needs of the membership in his region. The Region Director is also responsible to forward to the District Director any problem or dispute irresolvable at the Region level or below.

C. Area Director

The Area Director is responsible for presenting the "image" of QSAC to the membership and general public, and is the first-level provider of member-services. The Area Director is responsible to the organization and the membership to be the mediator of local disputes and to listen and redirect member input to the Region level and above. He/she is in charge of the interpretation and enforcement of QSAC procedures and rules when he/she is the ranking QSAC official on site. First and foremost, however, is the responsibility to serve the membership in his/her area, and ensure fair and equitable treatment of the membership. The Area Director is also responsible to forward to the Region Director any problem or dispute irresolvable at the Area level.

QUARTER SCALE AUTO CLUB, Inc.

Organizational Chart

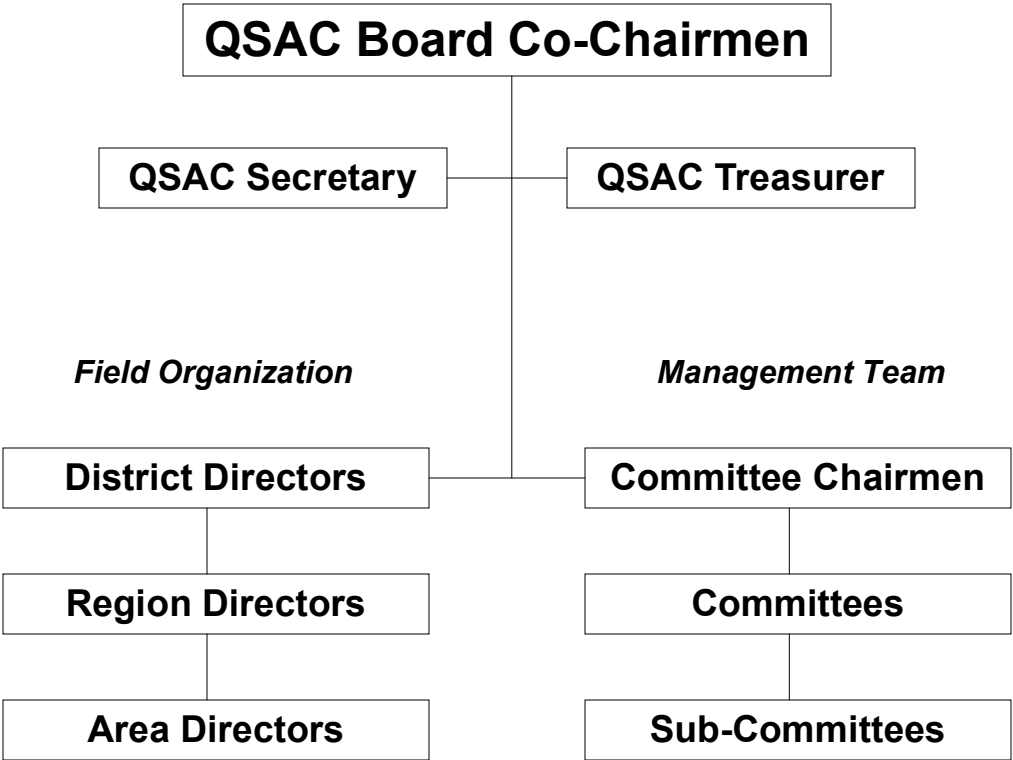

PLACE
STAMP
HERE

**QSAC Rules Committee
c/o Scott Schramske
5704 Turtle Lake Rd.
Shoreview, Minnesota 55126**



2011 QSAC Membership Application

(print) Name: _____ **Signature:** _____
(print) Street: _____
(print) City: _____ **State:** _____ **Zip:** _____
(print) Phone Number: _____ **E-mail Address:** _____

PLEASE PLACE AN "X" IN THE BOX NEXT TO YOUR SELECTION>>>>>>>	MAILED NEWSLETTER	DOWNLOADED NEWSLETTER	QSAC PARTNERS BENEFITS
Full Membership (Includes full QSAC insurance)	\$60.00 ()	\$40.00 ()	Yes
2nd Family Membership (Includes full QSAC insurance and must be in the same household)	N/A	\$35.00 ()	Yes
Mechanics License (See Note #1)	N/A	\$30.00 ()	No
One Day Drivers License (See Note #2)	N/A	\$30.00 ()	No

Note #1: A mechanics license MUST be obtained through a "Licensed To Race" QSAC member. This license will only permit the holder in the "Hot Pit" area, it will not insure him/her to drive a car. The currently licensed QSAC member sponsoring a Mechanic, MUST list their QSAC number below.

QSAC Member number sponsoring this Mechanics License _____

Note #2: The "One Event Driver's License" provides Driver's Insurance for one person for one day or one event and can only be used once per year. You **will not** be eligible for QSAC Partners Benefits. The \$20.00 fee can later be applied toward the purchase of a "Full Membership" for the same year. If a driver wishes to enter a second event after they have used the "One Day" license, he or she must then pay an additional \$40.00 or \$20.00 depending upon which newsletter choice is made. This will provide them with a "Full Membership" thru the end of the year with all membership benefits included. It is the driver's responsibility to provide proof of the original "One Day" membership.

Note #3: The membership period runs from October 31st thru December 31st of the following year.

Note #4: Membership applications received after August 1st will be valid thru December 31st of the same year. The membership fee will be reduced 25%. This policy applies to the "Full Membership" classification only. Please note that the QSAC insurance is based on a fixed cost per member NOT per time period.

Note #5: Membership fees may vary each year.

Note #6: "Full Memberships" received by March 31st, 2011 will be eligible for the QSAC Partners drawing which is being held on September 18th, 2011 at the QSAC Showdown N.C.S. (The Final Showdown) Race.

Note #7: Please allow 30 days from the time of sign up for all QSAC Partners Benefits to become activated.

Amount Enclosed: _____ Date: _____

New Member () Renewal Member () Current QSAC # _____

Make Checks Payable To: QSAC
 Mail To: QSAC, 15166 Center Road, East Lansing, MI. 48823

2011 QSAC Membership Receipt (If applied for at the track)

(print) NAME: _____ **Signature:** _____